









straub 
the original
an *Oliaxis* company

50 YEARS

RELIABLE
CONNECTION TECHNOLOGY
WITHOUT COMPROMISES
STRAUB PIPE COUPLINGS

STRAUB Manual

CONTENTS

50 YEARS STRAUB	4
THE PRINCIPLE	8
TECHNICAL PROPERTIES	9
STRAUB PIPE COUPLINGS - AXIAL RESTRAINT	
 STRAUB-METAL-GRIP	16
 STRAUB-GRIP STRAUB-GRIP-L	16
 STRAUB-FIRE-FENCE	17
 STRAUB-ECO-GRIP	26
 STRAUB-COMBI-GRIP	28
 STRAUB-PLAST-GRIP	28
FITTING INSTRUCTION STRAUB-GRIP	32
 STRAUB-PLAST-PRO DIN + MULTILAYER	34
STRAUB PIPE COUPLINGS - NON-AXIAL RESTRAINT	
SPECIFICATION	50
 STRAUB-FLEX	51
 STRAUB-OPEN-FLEX (GT)	57
 STRAUB-OPEN-FLEX-FIRE-FENCE	66
 STRAUB-STEP-FLEX	69
 STRAUB-SQUARE-FLEX	72
STRAUB REPAIR PRODUCTS	
 STRAUB-REP-FLEX	75
 STRAUB-CLAMP	78
STRAUB SHAPED PARTS	81
ACCESSORIES	
STRIP INSERTS	87
STIFFENING RINGS	88
FITTING TOOLS	89
SEALING SLEEVES LOCK PARTS EARTHING CONDUCTOR THRUST PROTECTORS	92
STRAUB LABEL	94
INSTALLATION INSTRUCTIONS	95
PIPE DIMENSIONS TABLE	103
PIPE GAP	104
DIMENSIONS AND WALL THICKNESS	105
ASSEMBLY SET-UP TIME	106
MATERIAL SPECIFICATIONS	107
CORROSION PROTECTION	108
SHIPBUILDING	111
STRAUB FIRE PROTECTION SYSTEM	115
ADVANTAGES FOR SHIPBUILDING	116
SHIPBUILDING REFERENCES	118
APPROVALS	120
TECHNICAL SHORT CHECK LIST	124
GTC general terms and conditions	126

50 YEARS

STRAUB PIPE COUPLINGS

«Develop a new, good idea and implement it consistently in a new, good product»

Immanuel Straub

STRAUB Werke AG celebrated its 50th anniversary in 2017. What started in 1967 with the invention of the STRAUB pipe connection is a global successful brand today.

“The STRAUB pipe connection is not an accidental invention but the result of systematic study of the problem.”

There were always numerous possibilities for connecting pipes. That require a lot of special knowledge paired with keeping extensive stock.

Immanuel Straub set himself the objective of bringing order to this “clutter”. During this research and development work, he found a universal pipe connection concept that

can be applied very easily and very quickly, nevertheless provides the greatest reliability: the STRAUB pipe connection!

This innovative solution permanently revolutionised pipe connection technology. The quick, easy and reliable “straubING” took the place of welding or flange connections.

Thanks to its ingenious concept, the original STRAUB coupling is regarded as one of the best innovations in the global market of pipe connection technology.



First mechanical STRAUB coupling



First hydraulic, axial restraint STRAUB coupling



Current STRAUB coupling

Immanuel Straub:







«To concentrate and commit where you can do more than others is another maxim!»

50 YEARS



OUR PERFORMANCE

YOUR ADVANTAGE

	COMPATIBILITY	⇒	STOCK REDUCTION
	SYSTEM INDEPENDENCE	⇒	FREE CHOICE OF PIPE SUPPLIER
	RELIABILITY	⇒	REDUCTION OF REWORK
	EFFICIENCY	⇒	RAPID INSTALLATION TIMES
	SAFETY	⇒	PERSONAL AND ENVIRONMENTAL PROTECTION
	SERVICE	⇒	MANUFACTURER'S TECHNICAL SUPPORT
	QUALITY	⇒	CONSISTENT QUALITY ASSURED

 THE STRAUB **5-YEAR** GUARANTEE!

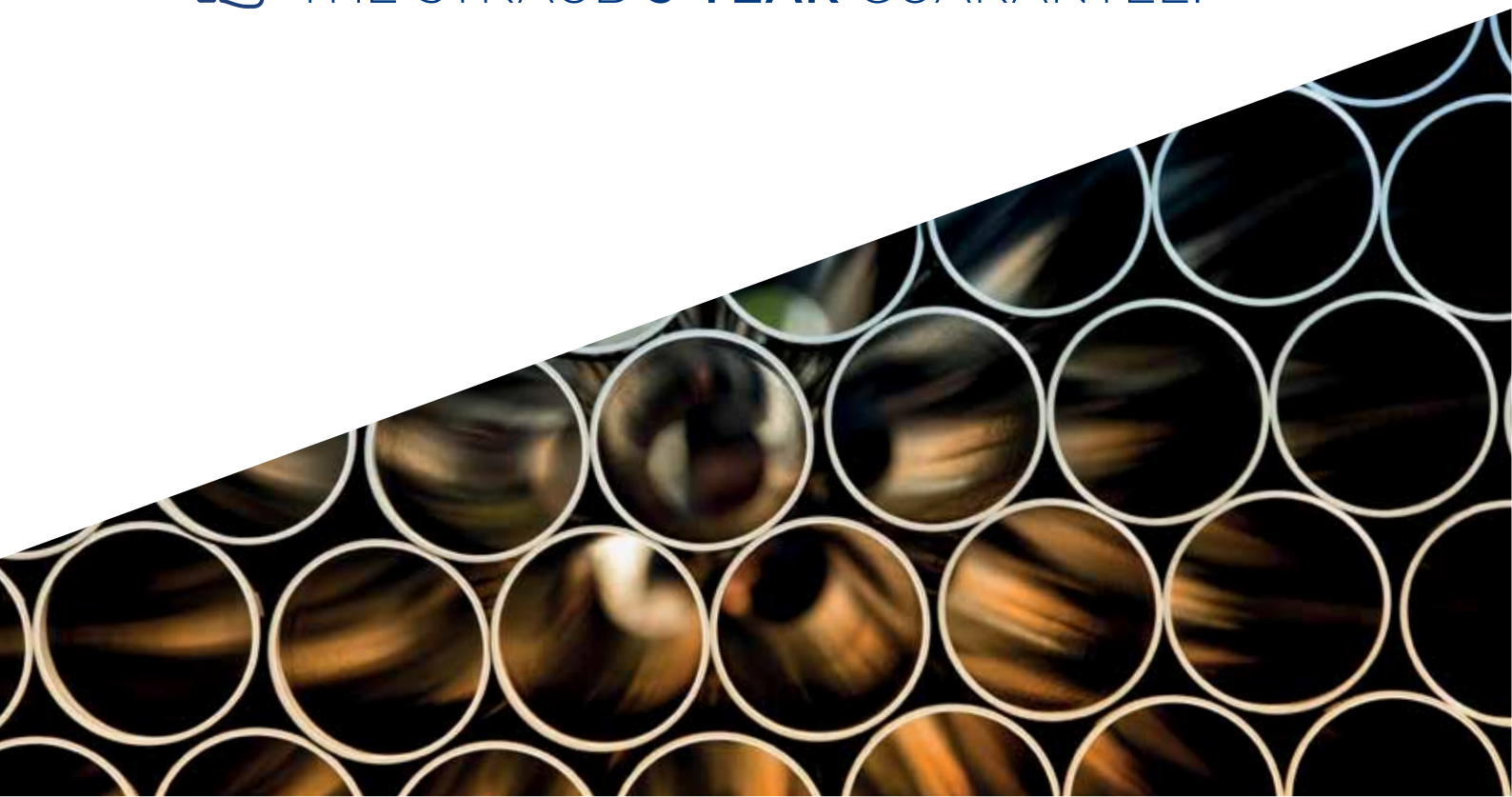

FEATURES AND BENEFITS

UNIVERSAL USE

- Compatible with almost any traditional jointing system
- Joins pipes of the same or dissimilar materials
- Leakproof joint for liquids, gas and solids
- Quick and simple repairs of damaged pipes without service interruptions

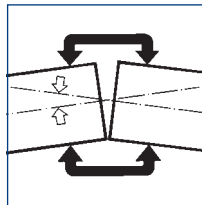
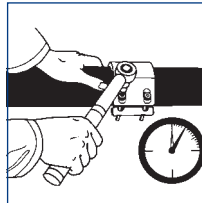

RELIABLE

- Stress-free, flexible pipe joint
- Compensates axial movement and angular deflection
- Pressure-resistant and leak-proof even with inaccurate pipe assembly
- Dampens water-hammer, vibration and structure-borne noise

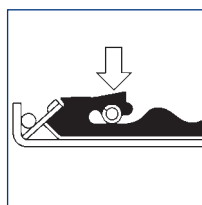
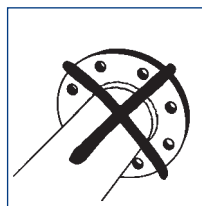

DURABLE

- Progressive sealing- and anchoring effect
- Corrosion- and temperature resistant
- Good resistance to chemicals
- Long service life

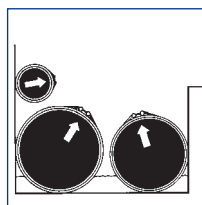

ECONOMICAL

- Pre-assembled design ensures simple and rapid installation
- For use on plain-end pipes without the need for costly pipe end preparation
- Simply cut pipes to length, center coupling and tighten bolts with a torque wrench
- No special assembly tools and set-up times

EASY HANDLING

- Detachable and reusable
- Maintenance-free and trouble-free
- No time-consuming alignment and fitting work
- Does not create a heat or fire hazard. The coupling can be fitted in special areas where there is a fire risk and also in confined spaces without the need for special equipment

SPACE-SAVING

- Compact design for space-saving installation of pipes
- Allows the use of low profile pipe insulation
- Low weight compared to traditional methods such as flanges

STRAUB COUPLINGS

THE BASIC CONCEPT



STRAUB-GRIP (axial restraint)

All STRAUB couplings designated with GRIP have axial restraint.

In order to be able to absorb the axial forces arising from the internal pressure, anchoring teeth engage in the relevant pipe material and provide a mechanical frictional connection. If the axial tensile load on the pipe increases due to increasing internal pressure, the teeth engage deeper into the pipe surface.



STRAUB-FLEX (axially flexible / non-axial restraint)

The STRAUB pipe couplings designated with FLEX are axially flexible (non-axial restraint).

If STRAUB-FLEX pipe couplings are used, it must be ensured that the occurring axial change in each pipe section is not greater than the compensation capability of the used STRAUB-FLEX pipe coupling. A fixed point and a sliding pipe restraint are required for each pipe section.

Depending on the size, the STRAUB-OPEN-FLEX is a foldable or several part FLEX pipe coupling.

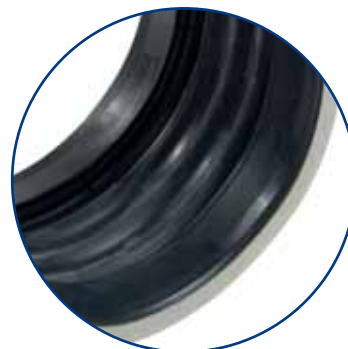
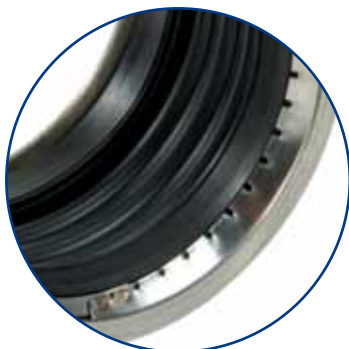

PROPERTIES

THE PROGRESSIVE SEALING EFFECT

The progressive sealing effect is a unique and patented feature of the STRAUB gasket.

- As the pressure in the pipe increases so does the force on the sealing lips, due to the flow through the pressure equalisation channel.
- The gasket is not subjected to any great loading thanks to the minimal installation torque applied. This results in continued elasticity and a long coupling life expectancy.
- The free space between the sealing lips serves as a „reservoir“ for the gasket in the event of temperature swings.



THE PROGRESSIVE ANCHORING EFFECT

STRAUB pipe couplings are used on conventional plain ended pipes without pipe end preparation being necessary. The progressive anchoring effect of all STRAUB-GRIP products is a unique and patented feature:

- As the bolts are tightened to the specified torque, the specially shaped teeth in the anchoring ring bite into the surface of the pipe. An axial restraint connection is created.
- Should the axial loading on the pipe increase due to increased internal pressure or external influences, the teeth bite even deeper into the pipe to compensate.
- There are STRAUB anchoring systems not only for hard surfaces such as iron, copper and steel but also for softer surfaces such as aluminium and plastic.
- Through differential hardening, the anchoring ring retains flexibility in service.

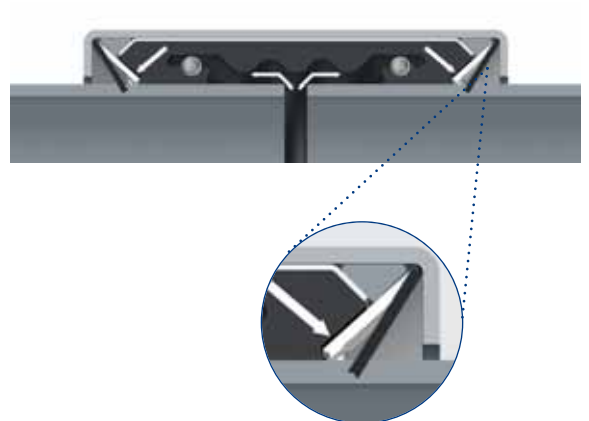

STRESS-FREE JOINING

The sealing and anchoring functions are independent of one another in STRAUB pipe couplings.

Anchoring

The spring effect of the housing and the anchoring ring result in a flexible gripping connection.

The housing which bridges the pipe ends imparts no forces and thereby keeps the stress on the various components to a minimum. The pipework is therefore not rigid but is flexible at every joint.



Sealing

The gasket is positioned on the surface of the pipe and enables the pipe ends to move freely.

DAMPING PROPERTIES

Due to the high amount of sealing rubber and based on the progressive anchoring and sealing mechanism, high damping effects are achieved. No additional compensation needed.

Noise- and Vibration damping

Sensor-testing proves remarkable acoustic benefits:

⇒ up to 7 times better sound absorption by STRAUB-FLEX as compared to flanges!

Electro-dynamic oscillating circuit tests at the turbine manufacturers site are proving damping values as shown:

- STRAUB-GRIP: 2.25 x better as flange
- STRAUB-FLEX: 7.5 x better as flange

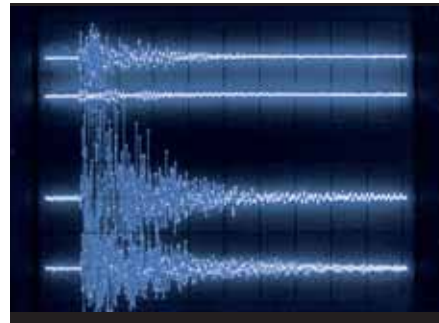

STRAUB-GRIP
STRAUB-FLEX

welded

flange

Above mentioned system is showing remarkable advantages in comparison to flanges:

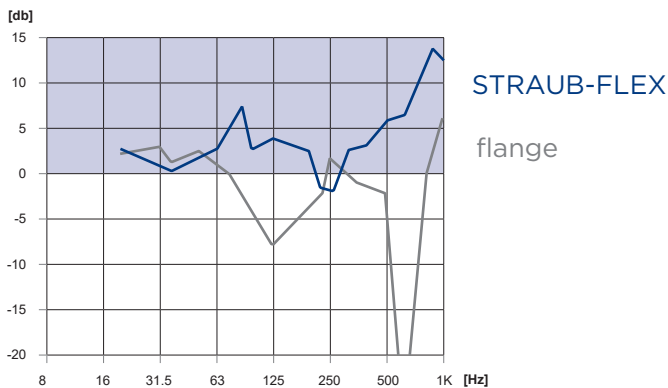

Positive values reflect vibration damping and negative values vibration reinforcement!

Application Benefits

On oscillating machines like engines, gears, turbines, generators etc.

- No tension transfer
- Interrupts oscillating circuits
- No loadfractures
- Increased life expectancy

For transitions between oscillating and rigid installations like engine to hull, pump to pipeline, fuel pump to feeds etc.

- Stress-free installation
- Flexible pipe system
- Coupling and compensator in one
- Quick detachable

Balancing of pressure surges & Shock resistance

Generating a pressure surge of 13 bar by 25 kg hammer:

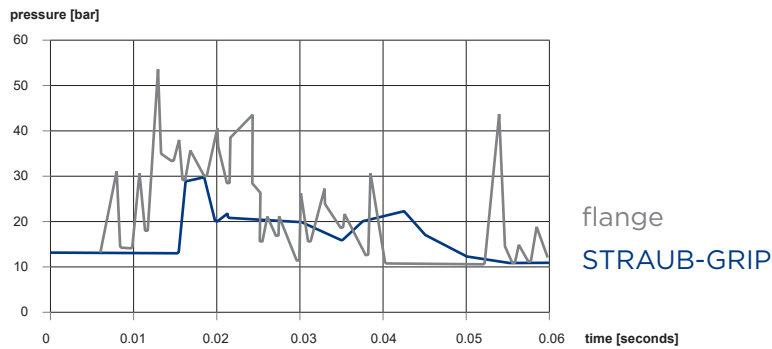

⇒ STRAUB couplings result in a four times lower value than flanges!

- No retightening of bolts
- Increased life expectancy
- Pipe elasticity
- No additional compensating costs
- Resistant against underwater blasts
- Acts flexible during collisions
- Tight even under deformed condition
- Increased life expectancy due to tension free systems



Pressure pulsation testing by the French Navy

Amplitude: 0 - 16 bar
 Frequency: 0.5 Hz
 STRAUB-GRIP-L: 660'000 cycles

Medium weight anvil shock test machine Canadian Department of National Defense:

Hammer Drop: 1 m
 Weight: 1700 kg
 Acceleration: ca. 150g

Shock Test WTD71/BWB BV0440

(for CuNiFe and steel pipes)

Acceleration: 140 g surface ships
 Acceleration: 200 g submarines

Earth quake Research Laboratory at Nippon Foundation:

1000 gal without damage
 (gal = dimension for acceleration)

LIFE EXPECTANCY

The life expectancy of STRAUB pipe joints and STRAUB repair clamps fitted with sealing sleeves made of EPDM, NBR or FKM/FPM extend to 25 year or more, provided that recommended storage procedures are correctly adhered to.

Application conditions

Increased temperature

The max. application temperature of EPDM is 125°C/250°F and NBR 100°C/230°F, but as a consequence the life span can be reduced. In addition dynamical and chemical stress has to be taken into consideration. For different applications please verify the life expectancy with the manufacturer.

Low temperature:

Subject to performance requirements the elasticity of STRAUB sealing sleeves is sufficient to cope with temperatures down to -30°C/-22°F. There is a loss of elasticity below this point which, under the stress of additional dynamic loading, can result in disruption of the elastomer.

The coupling casing and the anchoring ring (GRIP) completely enclose the sealing sleeve and therefore protect it from UV irradiation.

Because of their progressive sealing effect, STRAUB sealing sleeves require a smaller tightening force and therefore subjected to less stress than, say, a flange seal. The elasticity and hence the working life of STRAUB sealing sleeves is consequently maintained over a longer period.

Storage

Recommended long term storage conditions:

- Avoid exposure to direct sunlight by storing inside
- Store at consistent temperatures (maximum 40°C/104°F)
- The relative humidity should be kept above 50 %
- Protect from dirt or soiling



THE STRAUB MAIN RANGE OF APPLICATION

The installation of a STRAUB pipe joint is fast, simple and reliable - even under the most demanding circumstances, anywhere in the world is the STRAUB philosophy.

The STRAUB applications and opportunities:

WATER & GAS

- Water lines
- Gas lines
- Wells
- Hydrant lines
- Tank lines
- Sludge lines
- Drainage lines
- Chemical lines
- Airation lines

GROUNDWORK & INDUSTRY

- Sanitary lines
- Fire fighting lines
- Ventilation lines
- Cooling lines
- Lubrication lines
- Utility lines
- Fuel lines
- Penstock lines
- Turbine lines
- Transport lines

SHIPBUILDING & OFFSHORE

- Fire fighting lines
- Vent lines
- Sea water cooling systems
- Ballast lines
- Fuel lines





ELEMENTARY FORCES

RELIABLY UNDER CONTROL





AXIAL
RESTRAINT
PIPE COUPLINGS

CONNECT METAL PIPES WITH **STRAUB-METAL-GRIP** and **STRAUB-GRIP**

STRAUB-METAL-GRIP and STRAUB-GRIP pipe couplings are pipe connections with axial restraint for all metal pipes and rigid plastics.

There are countless possible uses on almost all pipe systems due to the universal connection solution. The installation is performed on smooth-ended pipes without any pipe end machining.

The compact design allows pipe routing in very confined spaces.

Unexpected secondary stresses and arising inaccuracies for the pipe routing on-site are accommodated by the couplings due to the flexible design. This enables simple and quick installation that results in noticeable cost savings.



STRAUB-METAL-GRIP

- Outside diameter: 30.0 up to 609.6mm
- Temperature: -30°C up to +100°C
- Sealing sleeve: EPDM, NBR



STRAUB-GRIP

- Outside diameter: 25.0 up to 711.2 mm
- Temperature: -20°C up to +180°C
- Sealing sleeve: EPDM, NBR, FPM/FKM



FIRE RESISTANT & SAFE

STRAUB-FIRE-FENCE

The original STRAUB fire protection system for applications where fire protection is required.



- Outside diameter: 26.9 up to 457.2 mm
- Temperature: -30°C up to +180°C
- Sealing sleeve: EPDM, NBR, FPM/FKM

With ISO 19921 and ISO 19922, the STRAUB-FIRE-FENCE types meet the highest global standardised requirements for fire and temperature tests.

STRAUB FIRE-FENCE is the optimum solution for fire extinguishing equipment and for many different systems with increased fire protection requirements such as in civil engineering (tunnels), for shipyards for seagoing vessels with various requirements and other applications.

The STRAUB-FIRE-FENCE system is based on the standard types of the STRAUB-GRIP and STRAUB-FLEX series. An intumescent plastic is also firmly bonded to the outside of the casing. In the event of fire, this swells and protectively encloses the pipe coupling - and retains the complete functional capability in doing so.



Thus all advantages of the STRAUB pipe couplings are combined with fire protection and give the user a simple, space-saving, state-of-the-art pipe connection.



Already installed STRAUB couplings can be easily and quickly converted to the STRAUB-FIRE-FENCE variant using the separately available retrofit kit; available for the STRAUB-GRIP, STRAUB-METAL-GRIP and STRAUB-FLEX product groups.

Components / Materials	W1	W2	W4	W5
Casing		AISI 316 L	AISI 304	AISI 316 L or similar
Bolts		AISI 4135	A4 - 80	A4 - 80
Bars		AISI 12L14, galvanised	AISI 304	AISI 316 L or similar
Anchoring rings		AISI 301	AISI 301	AISI 301
Strip insert (option)		AISI 316 L or similar / PVDF	AISI 316 L / PVDF	AISI 316 L or similar / PVDF

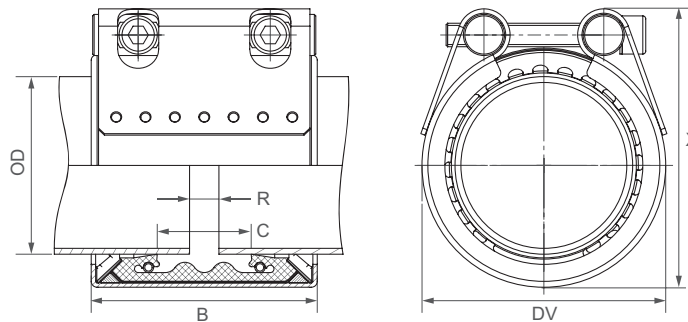

Sealing sleeve EPDM	Temp.: -30°C up to +100°C
	Medium: all qualities of water, waste water, air, solids and chemical products
Sealing sleeve NBR	Temp.: -20°C up to +80°C
	Medium: water, gas, oil, fuel and other hydrocarbons



OD [mm]	Clamping range [mm]	PN [bar]	PN [bar]	B [mm]	C [mm]	DV [mm]	X [mm]	R without strip insert [mm]	R with strip insert [mm]	Torque rate [Nm]	Allen head [mm]	Thread M...
30.0	29.5 - 30.5	67	16	46/67	18	47	56	5	5	10	6	8
33.7	33.2 - 34.2	62	16	46/67	18	52	63	5	5	10	6	8
38.0	37.5 - 38.5	58	16	61	19	58	73	5	5 - 10	15	6	8
42.4	41.9 - 42.9	53	16	61	20	62	76	5	5 - 10	15	6	8
44.5	44.0 - 45.0	48	16	61	20	64	80	5	5 - 10	15	6	8
48.3	47.8 - 48.8	44	16	61	20	68	83	5	5 - 10	15	6	8
54.0	53.5 - 54.5	39	16	77	38	74	89	5	5 - 15	15	6	8
57.0	56.4 - 57.6	37	16	77	32	77	92	5 - 10	5 - 25	15	6	8
60.3	59.7 - 60.9	37	16	77	32	82	95	5 - 10	5 - 25	15	6	8
63.5	62.9 - 64.1	37	16	77	32	84	98	5 - 10	5 - 25	15	6	8
73.0	72.2 - 73.8	56	16	94	39	95	117	5 - 10	5 - 25	35	8	10
76.1	75.3 - 76.9	56	16	94	39	100	117	5 - 10	5 - 25	35	8	10
84.0	83.2 - 84.8	45	16	94	39	112	123	5 - 10	5 - 25	35	8	10
88.9	88.0 - 89.8	41	16	94	39	117	123	5 - 10	5 - 25	35	8	10
104.0	103.0 - 105.0	37	16	94	39	133	151	5 - 10	5 - 25	35	8	10
108.0	106.9 - 109.1	35	16	94	39	133	151	5 - 10	5 - 25	35	8	10
114.3	113.2 - 115.4	34	16	94	39	139	157	5 - 10	5 - 25	35	8	10
129.0	127.7 - 130.3	33	16	108	43	160	182	5 - 15	5 - 25	60	10	12
133.0	131.7 - 134.3	33	16	108	43	160	182	5 - 15	5 - 25	60	10	12
139.7	138.3 - 141.1	32	16	109	43	168	191	5 - 15	5 - 25	60	10	12
154.0	152.5 - 155.5	32	16	109	51	186	210	5 - 15	5 - 25	60	10	12
159.0	157.4 - 160.6	31	16	109	43	187	210	5 - 15	5 - 25	60	10	12
168.3	166.6 - 170.0	29	16	109	43	200	220	5 - 15	5 - 25	60	10	12
219.1	216.9 - 221.3	26	16	150	60	259	288	5 - 15	5 - 35	100	14	16

REFER TO MINIMUM WALL THICKNESS (see page 105)

Remarks:

- Follow fitting instructions
- PN () = working pressure considering the application loads
Test pressure = PN () x 1.5 (for example industry, water supply etc.)
PN () = nominal pressure, includes four times safety factor (e.g. shipbuilding)
- The pressure values are valid on radial rigid carbon steel pipes under static loads
- Strip inserts are optional accessories (see page 87)
- Additional sealing sleeves and temperature ranges on request

Components / Materials	W1	W2	W4	W5
Casing	AISI A738, hot-dip galvanised			
Bolts	AISI 4135			
Bars	AISI 12L14, galvanised			
Anchoring rings	AISI 301			
Strip insert (option)	AISI 316 L or similar / PVDF			
Sealing sleeve EPDM	Temp.: -20°C up to +100°C Medium: all qualities of water, waste water, air, solids and chemical products			
Sealing sleeve NBR	Temp.: -20°C up to +80°C Medium: water, gas, oil, fuel and other hydrocarbons			

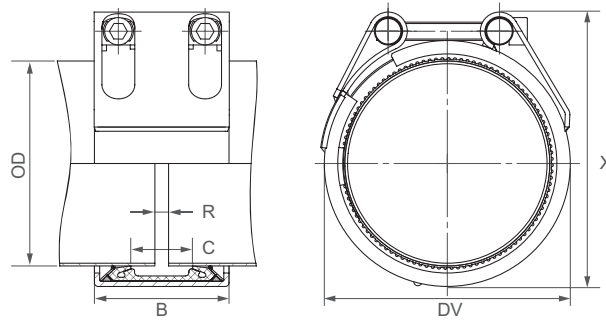

OD [mm]	Clamping range [mm]	PN [bar]	PN [bar]	B [mm]	C [mm]	DV [mm]	X [mm]	R without strip insert [mm]	R with strip insert [mm]	Torque rate [Nm]	Allen head [mm]	Thread M...
180.0	178.0 - 182.0	29	16	148	67	225	256	5 - 15	5 - 35	150	17	20
193.7	192.0 - 195.5	29	16	148	67	239	270	5 - 15	5 - 35	150	17	20
200.0	198.0 - 202.0	28	15	148	67	245	276	5 - 15	5 - 35	180	17	20
206.0	204.0 - 208.0	28	15	148	67	251	282	5 - 15	5 - 35	180	17	20
244.5	242.0 - 247.0	27	14	148	67	290	330	5 - 15	5 - 35	180	17	20
267.0	264.5 - 269.5	24	12	148	67	312	352	5 - 15	5 - 35	180	17	20
273.0	270.5 - 275.5	21	12	148	67	318	359	5 - 15	5 - 35	180	17	20
323.9	320.5 - 327.0	18	10	148	67	369	411	5 - 15	5 - 35	230	17	20
355.6	352.0 - 359.0	17	8	148	67	401	444	5 - 15	5 - 35	230	17	20
406.4	402.5 - 410.5	14	8	148	67	451	494	5 - 15	5 - 35	230	17	20
457.2	452.5 - 462.0	8	6	148	67	502	546	5 - 15	5 - 35	250	17	20
508.0	503.0 - 513.0	6	5	148	67	553	598	5 - 15	5 - 35	250	17	20
558.8	554.0 - 564.0	6	4.5	148	67	604	649	5 - 15	5 - 35	300	17	20
609.6	604.5 - 614.5	5	4	148	67	655	701	5 - 15	5 - 35	300	17	20

**CONTINUOUSLY VARIABLE INTERMEDIATE SIZES FROM 180.0 TO 609.6 mm ARE AVAILABLE
REFER TO MINIMUM WALL THICKNESS (see page 105)**

Remarks:

- Follow fitting instructions
- PN (🏭) = working pressure considering the application loads
Test pressure = PN (🏭) x 1.5 (for example industry, water supply etc.)
PN (🚢) = nominal pressure, includes four times safety factor (e.g. shipbuilding)
- The pressure values are valid on radial rigid carbon steel pipes under static loads
- Strip inserts are optional accessories (see page 87)
- Additional sealing sleeves and temperature ranges on request

Components / Materials	W1	W2	W4	W5
Casing		AISI 316 L		AISI 316 L or similar
Bolts		AISI 4135		A4 - 80
Bars		AISI 12L14, galvanised		AISI 316 L or similar
Anchoring rings		AISI 301		AISI 301
Strip insert (option)		AISI 316 L or similar / PVDF		AISI 316 L or similar / PVDF

Sealing sleeve EPDM	Temp.: -30°C up to +100°C			
	Medium: all qualities of water, waste water, air, solids and chemical products			
Sealing sleeve NBR	Temp.: -20°C up to +80°C			
	Medium: water, gas, oil, fuel and other hydrocarbons			

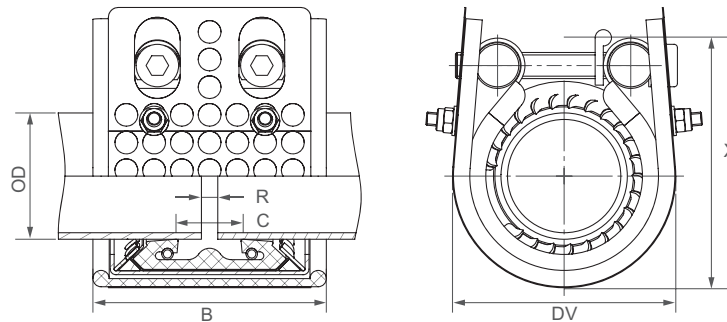

OD [mm]	Clamping range [mm]	PN [bar]	PN [bar]	B [mm]	C [mm]	DV [mm]	X [mm]	R without strip insert [mm]	R with strip insert [mm]	Torque rate [Nm]	Allen head [mm]	Thread M...
30.0	29.5 - 30.5	67	16	46/67	18	57	61	5	5	10	6	8
33.7	33.2 - 34.2	62	16	46/67	18	62	68	5	5	10	6	8
38.0	37.5 - 38.5	58	16	71	19	68	78	5	5 - 10	15	6	8
42.4	41.9 - 42.9	53	16	71	20	72	81	5	5 - 10	15	6	8
44.5	44.0 - 45.0	48	16	71	20	74	85	5	5 - 10	15	6	8
48.3	47.8 - 48.8	44	16	71	20	78	88	5	5 - 10	15	6	8
54.0	53.5 - 54.5	39	16	87	38	84	94	5	5 - 15	15	6	8
57.0	56.4 - 57.6	37	16	87	32	87	97	5 - 10	5 - 25	15	6	8
60.3	59.7 - 60.9	37	16	87	32	87	100	5 - 10	5 - 25	15	6	8
63.5	62.9 - 64.1	37	16	87	32	94	103	5 - 10	5 - 25	15	6	8
76.1	75.3 - 76.9	56	16	110	39	110	122	5 - 10	5 - 25	35	8	10
84.0	83.2 - 84.8	45	16	110	39	122	128	5 - 10	5 - 25	35	8	10
88.9	88.0 - 89.8	41	16	110	39	127	128	5 - 10	5 - 25	35	8	10
104.0	103.0 - 105.0	37	16	110	39	143	156	5 - 10	5 - 25	35	8	10
108.0	106.9 - 109.1	35	16	110	39	143	156	5 - 10	5 - 25	35	8	10
114.3	113.2 - 115.4	34	16	110	39	149	162	5 - 10	5 - 25	35	8	10
129.0	127.7 - 130.3	33	16	124	43	170	187	5 - 15	5 - 25	60	10	12
133.0	131.7 - 134.3	33	16	125	43	170	187	5 - 15	5 - 25	60	10	12
139.7	138.3 - 141.1	32	16	125	43	178	196	5 - 15	5 - 25	60	10	12
154.0	152.5 - 155.5	32	16	125	51	196	215	5 - 15	5 - 25	60	10	12
159.0	157.4 - 160.6	31	16	125	43	197	215	5 - 15	5 - 25	60	10	12
168.3	166.6 - 170.0	29	16	125	43	210	225	5 - 15	5 - 25	60	10	12
219.1	216.9 - 221.3	26	16	166	60	269	293	5 - 15	5 - 35	100	14	16

REFER TO MINIMUM WALL THICKNESS (see page 105)

Remarks:

- Follow fitting instructions
- PN () = working pressure considering the application loads
Test pressure = PN () x 1.5 (for example industry, water supply etc.)
PN () = nominal pressure, includes four times safety factor (e.g. shipbuilding)
- The pressure values are valid on radial rigid carbon steel pipes under static loads
- Additional sealing sleeves and temperature ranges on request

Components / Materials	W1	W2	W4	W5
Casing	AISI A738, hot-dip galvanised			
Bolts	AISI 4135			
Bars	AISI 12L14, galvanised			
Anchoring rings	AISI 301			
Strip insert (option)	AISI 316 L or similar / PVDF			
Sealing sleeve EPDM	Temp.: -20°C up to +100°C Medium: all qualities of water, waste water, air, solids and chemical products			
Sealing sleeve NBR	Temp.: -20°C up to +80°C Medium: water, gas, oil, fuel and other hydrocarbons			

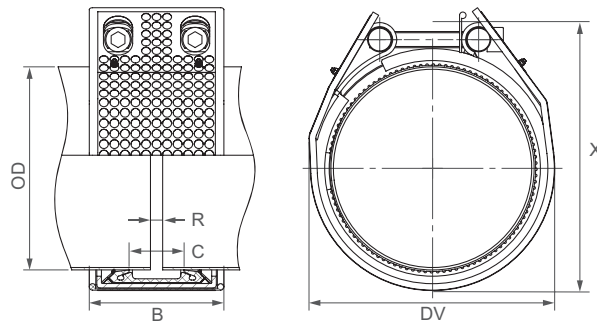

OD [mm]	Clamping range [mm]	PN [bar]	PN [bar]	B [mm]	C [mm]	DV [mm]	X [mm]	R without strip insert [mm]	R with strip insert [mm]	Torque rate [Nm]	Allen head [mm]	Thread M...
244.5	242.0 - 247.0	27	14	164	67	300	335	5 - 15	5 - 35	180	17	20
267.0	264.5 - 269.5	24	12	164	67	322	357	5 - 15	5 - 35	180	17	20
273.0	270.5 - 275.5	21	12	164	67	328	364	5 - 15	5 - 35	180	17	20
323.9	320.5 - 327.0	18	10	164	67	379	416	5 - 15	5 - 35	230	17	20
355.6	352.0 - 359.0	17	8	164	67	411	449	5 - 15	5 - 35	230	17	20
406.4	402.5 - 410.5	14	8	164	67	461	499	5 - 15	5 - 35	230	17	20
457.2	452.5 - 462.0	8	6	164	67	512	551	5 - 15	5 - 35	250	17	20

REFER TO MINIMUM WALL THICKNESS (see page 105)

Remarks:

- Follow fitting instructions
- PN (🏭) = working pressure considering the application loads
Test pressure = PN (🏭) x 1.5 (for example industry, water supply etc.)
PN (🚢) = nominal pressure, includes four times safety factor (e.g. shipbuilding)
- The pressure values are valid on radial rigid carbon steel pipes under static loads
- Strip inserts are optional accessories (see page 87)
- Additional sealing sleeves and temperature ranges on request

Components / Materials	W1	W2	W4	W5
Casing				AISI 316 L / LDX 2101
Bolts				A4 - 80
Bars				AISI 316 L or similar
Anchoring rings				AISI 301
Strip insert (option)				AISI 316 L / PVDF

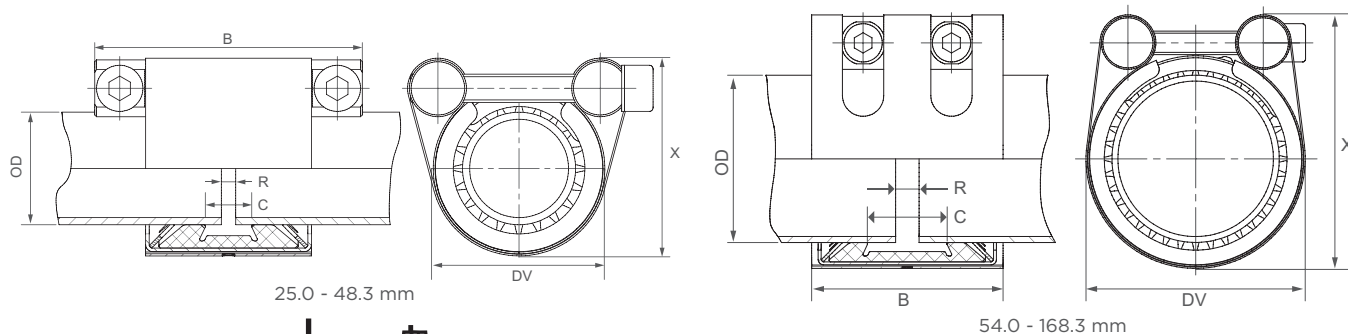

Sealing sleeve EPDM	Temp.: -20°C up to +100°C	Medium: all qualities of water, waste water, air, solids and chemical products
Sealing sleeve NBR	Temp.: -20°C up to +80°C	Medium: water, gas, oil, fuel and other hydrocarbons
Sealing sleeve FPM/FKM	Temp.: -20°C up to +180°C	Medium: ozone, oxygen, acids, gas, oil and fuel (only with strip insert)



OD [mm]	Clamping range [mm]	PN [bar]	PN [bar]	B [mm]	C [mm]	DV [mm]	X [mm]	R without strip insert [mm]	R with strip insert [mm]	Torque rate [Nm]	Allen head [mm]	Thread M...
21.3	21.0 - 21.6	36	16	46	18	43	56	5	5 - 10	10	5	6
25.0	24.5 - 25.5	64	16	46.5 / 75	18	41	53	5	5 - 10	10	6	8
26.9	26.4 - 27.4	58	16	46.5 / 75	18	44	56	5	5 - 10	10	6	8
28.0	27.5 - 28.5	50	16	46.5 / 75	18	45	57	5	5 - 10	10	6	8
30.0	29.5 - 30.5	42	16	46.5 / 75	18	47	60	5	5 - 10	10	6	8
33.7	33.2 - 34.2	39	16	46.5 / 75	18	51	65	5	5 - 10	10	6	8
35.0	34.5 - 35.5	37	16	46.5 / 75	18	52	66	5	5 - 10	12	6	8
38.0	37.5 - 38.5	36	16	46.5 / 75	18	55	69	5	5 - 10	12	6	8
40.0	39.5 - 40.5	35	16	46.5 / 75	18	57	71	5	5 - 10	12	6	8
42.4	41.9 - 42.9	33	16	46.5 / 75	18	60	74	5	5 - 10	12	6	8
44.5	44.0 - 45.0	30	16	46.5 / 75	18	62	76	5	5 - 10	12	6	8
48.3	47.8 - 48.8	28	16	46.5 / 75	18	65	81	5	5 - 10	12	6	8
54.0	53.5 - 54.5	24	16	65	24	71	87	5	5 - 15	15	6	8
57.0	56.4 - 57.6	23	16	65	24	74	90	5	5 - 15	15	6	8
60.3	59.7 - 60.9	23	16	65	24	77	93	5	5 - 15	15	6	8
63.0	62.4 - 63.6	23	16	65	24	80	96	5	5 - 15	15	6	8
66.6	64.9 - 67.3	22	16	65	24	84	100	5	5 - 15	15	6	8
70.0	68.9 - 70.7	22	16	65	24	87	104	5	5 - 15	15	6	8
73.0	72.3 - 73.7	21	16	65	24	90	107	5	5 - 15	15	6	8
76.1	75.3 - 76.9	35	16	100	40	100	122	5 - 10	5 - 25	20	8	10
79.5	78.7 - 80.3	32	16	100	40	103	125	5 - 10	5 - 25	20	8	10
84.0	83.2 - 84.8	29	16	100	40	107	130	5 - 10	5 - 25	20	8	10
88.9	88.0 - 89.8	26	16	100	40	112	134	5 - 10	5 - 25	20	8	10
95.0	94.0 - 96.0	24	16	100	40	117	139	5 - 10	5 - 25	25	8	10
98.0	97.0 - 99.0	24	16	100	40	121	143	5 - 10	5 - 25	35	8	10
100.6	99.6 - 101.6	23	16	100	40	124	146	5 - 10	5 - 25	25	8	10
101.6	100.6 - 102.6	23	16	100	40	125	146	5 - 10	5 - 25	25	8	10
104.0	103.0 - 105.0	23	16	100	40	127	148	5 - 10	5 - 25	25	8	10
104.8	103.8 - 105.8	23	16	100	40	128	150	5 - 10	5 - 25	25	8	10
108.0	106.9 - 109.1	22	16	100	40	132	154	5 - 10	5 - 25	25	8	10
114.3	113.2 - 115.4	22	16	100	40	138	160	5 - 10	5 - 25	25	8	10
118.0	116.9 - 119.1	22	16	100	40	142	166	5 - 10	5 - 25	35	8	10
122.0	120.6 - 123.4	21	16	115	53	149	170	5 - 10	5 - 30	35	10	12
125.0	123.7 - 126.3	21	16	115	53	152	174	5 - 10	5 - 30	40	10	12
127.0	125.7 - 128.3	21	16	115	53	154	176	5 - 10	5 - 30	40	10	12
129.0	127.7 - 130.3	21	16	115	53	156	178	5 - 10	5 - 30	40	10	12
130.2	128.9 - 131.5	21	16	115	53	157	179	5 - 10	5 - 30	40	10	12
133.0	131.7 - 134.3	21	16	115	53	160	182	5 - 10	5 - 30	40	10	12
139.7	138.3 - 141.1	20	16	115	53	166	189	5 - 10	5 - 30	40	10	12
141.3	139.9 - 142.7	20	16	115	53	168	190	5 - 10	5 - 30	40	10	12
144.0	142.6 - 145.4	20	16	115	53	171	183	5 - 10	5 - 30	60	10	12
154.0	152.5 - 155.5	18	16	115	53	181	203	5 - 10	5 - 30	50	10	12
159.0	157.4 - 160.6	18	16	115	53	186	208	5 - 10	5 - 30	50	10	12
165.0	163.4 - 166.6	16	16	115	53	192	214	5 - 10	5 - 30	50	10	12
168.3	166.6 - 170.0	16	16	115	53	195	217	5 - 10	5 - 30	50	10	12

REFER TO MINIMUM WALL THICKNESS (see page 105)

- Follow fitting instructions
- According to DIN 86128

- PN () = working pressure considering the application loads
Test pressure = PN () x 1.5 (for example industry, water supply etc.)
- PN () = nominal pressure, includes four times safety factor (e.g. shipbuilding)
- The pressure values are valid on radial rigid carbon steel pipes under static loads
- Strip inserts are optional accessories (see page 87)
- Additional sealing sleeves and temperature ranges on request

Components / Materials	W1	W2	W4	W5
Casing		AISI 316 L or similar		AISI 316 L or similar
Bolts		AISI 4135		A4 - 80
Bars		AISI 12L14, galvanised		AISI 316 L
Anchoring rings		AISI 301		AISI 301
Strip insert (option)		AISI 316 L or similar / HDPE		AISI 316 L or similar / HDPE

Sealing sleeve EPDM	Temp.: -20°C up to +100°C	Medium: all qualities of water, waste water, air, solids and chemical products
Sealing sleeve NBR	Temp.: -20°C up to +80°C	Medium: water, gas, oil, fuel and other hydrocarbons
Sealing sleeve FPM/FKM	Temp.: -20°C up to +180°C	Medium: ozone, oxygen, acids, gas, oil and fuel (only with strip insert)

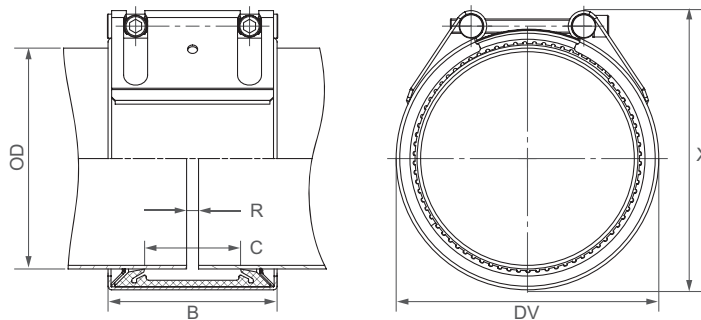

OD [mm]	Clamping range [mm]	PN [bar]	PN [bar]	B [mm]	C [mm]	DV [mm]	X [mm]	R without strip insert [mm]	R with strip insert [mm]	Torque rate [Nm]	Allen head [mm]	Thread M...
180.0	178.0 - 182.0	16	10	141	80	205	233	5 - 10	5 - 35	50	10	12
193.7	192.0 - 195.5	16	10	141	80	224	243	5 - 10	5 - 35	50	10	12
200.0	198.0 - 202.0	15	10	141	80	230	249	5 - 10	5 - 35	50	10	12
204.0	202.0 - 206.0	14	10	141	80	234	253	5 - 10	5 - 35	50	10	12
206.0	204.0 - 208.0	14	5.5	141	80	234	253	5 - 10	5 - 35	50	10	12
219.1	216.9 - 221.3	16	10	142	80	250	269	5 - 10	5 - 30	60	10	12
244.5	242.0 - 247.0	9	5.5	141	80	275	294	5 - 10	5 - 35	50	10	12
250.0	247.5 - 252.5	9	5.5	141	80	280	299	5 - 10	5 - 35	50	10	12
254.0	251.5 - 256.5	9	5.5	141	80	284	303	5 - 10	5 - 35	50	10	12
256.0	253.5 - 258.5	9	5.5	141	80	284	303	5 - 10	5 - 35	50	10	12
267.0	264.5 - 269.5	8	5	141	80	297	316	5 - 10	5 - 35	50	10	12
273.0	270.5 - 275.5	7	4	141	80	303	322	5 - 10	5 - 35	60	10	12
273.0	270.5 - 275.5	16	4	141	80	303	326	5 - 10	5 - 35	80	14	16
306.0	303.0 - 309.0	6	3	141	80	334	353	5 - 10	5 - 35	60	10	12
323.9	320.5 - 327.0	5	3	141	80	354	373	5 - 10	5 - 35	60	10	12
323.9	320.5 - 327.0	13	3	141	80	354	377	5 - 10	5 - 35	90	14	16
355.6	352.0 - 359.0	10	2.5	141	80	386	405	5 - 10	5 - 35	90	14	16
406.4	402.5 - 410.5	7	2	141	80	436	455	5 - 10	5 - 35	100	14	16
457.2	452.5 - 461.5	5	-	141	80	487	506	5 - 10	5 - 35	100	14	16
508.0	503.5 - 512.5	4	-	141	80	538	557	5 - 10	5 - 35	110	14	16
558.8	554.5 - 563.5	3	-	141	80	589	608	5 - 10	5 - 35	110	14	16
609.6	605.5 - 614.0	2	-	141	80	640	659	5 - 10	5 - 35	120	14	16
711.2	707.0 - 715.0	1	-	141	80	742	761	5 - 10	5 - 35	120	14	16

CONTINUOUSLY VARIABLE INTERMEDIATE SIZES FROM 180.0 TO 711.2 mm ARE AVAILABLE / REFER TO MINIMUM WALL THICKNESS (see page 105)

STRAUB-GRIP-L stepped coupling

OD		Clamping range		PN [bar]	B [wmm]	C [mm]	DV [mm]	R without strip insert [mm]	R with strip insert [mm]	Torque rate [Nm]	Allen head [mm]	Thread M...
Pipe 1 [mm]	Pipe 2 [mm]	OD 1 [mm]	OD 2 [mm]									
50.8	48.3	50.3 - 51.3	47.8 - 48.8	24	76	37	76	5	5 - 10	7.5	6	8
54.0	50.8	53.5 - 54.5	50.3 - 51.3	24	76	37	76	5 - 10	5 - 10	7.5	6	8
60.3	57.0	59.7 - 60.9	56.4 - 57.6	24	76	37	79	5 - 10	5 - 15	7.5	6	8
76.1	73.0	75.3 - 76.9	72.3 - 73.7	24	95	41	98	5 - 10	5 - 25	12	6	8
88.9	84.0	88.0 - 89.8	83.2 - 84.8	22	95	41	111	5 - 10	5 - 25	12	6	8
104.0	101.6	103.0 - 105.0	100.6 - 102.6	22	95	35	132	5 - 10	5 - 25	12	6	8
108.0	104.8	106.9 - 109.1	103.8 - 105.8	21	95	41	130	5 - 10	5 - 25	12	6	8
114.3	108.0	113.2 - 115.4	106.9 - 109.1	16	95	41	136	5 - 10	5 - 25	12	6	8
139.7	133.0	138.3 - 141.1	131.7 - 134.3	16	110	54	164	5 - 10	5 - 30	20	8	10
159.0	154.0	157.4 - 160.6	152.5 - 155.5	16	110	54	183	5 - 10	5 - 30	20	8	10
168.3	159.0	166.6 - 170.0	157.4 - 160.6	16	110	54	192	5 - 10	5 - 30	20	8	10

- Follow fitting instructions
- PN () = working pressure considering the application loads
Test pressure = PN () x 1.5 (for example industry, water supply etc.)

- PN () = nominal pressure, includes four times safety factor (e.g. shipbuilding)
- The pressure values are valid on radial rigid carbon steel pipes under static loads
- Strip inserts are optional accessories (see page 87)
- Additional sealing sleeves and temperature ranges on request

Typing errors may occur. Technical details are subject to change.

Components / Materials	W1	W2	W4	W5
Casing				AISI 316 L or similar
Bolts				A4 - 80
Bars				AISI 316 L or similar
Anchoring rings				AISI 301
Strip insert (option)				AISI 316 L / PVDF

Sealing sleeve EPDM	Temp.: -20°C up to +100°C	Medium: all qualities of water, waste water, air, solids and chemical products
Sealing sleeve NBR	Temp.: -20°C up to +80°C	Medium: water, gas, oil, fuel and other hydrocarbons
Sealing sleeve FPM/FKM	Temp.: -20°C up to +180°C	Medium: ozone, oxygen, acids, gas, oil and fuel (only with strip insert)

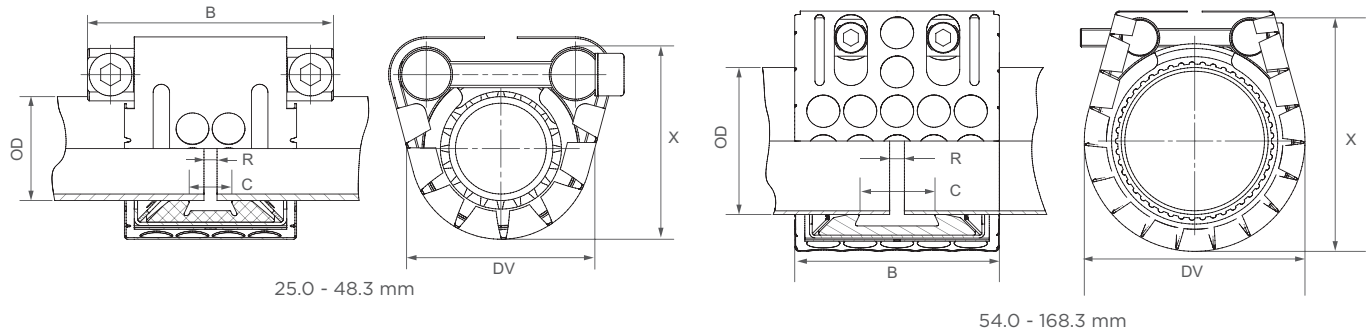

OD [mm]	Clamping range [mm]	PN [bar]	PN [bar]	B [mm]	C [mm]	DV [mm]	X [mm]	R without strip insert [mm]	R with strip insert [mm]	Torque rate [Nm]	Allen head [mm]	Thread M...
25.0	24.5 - 25.5	64	16	46.5 / 75	18	51	58	5	5 - 10	10	6	8
26.9	26.4 - 27.4	58	16	46.5 / 75	18	54	61	5	5 - 10	10	6	8
28.0	27.5 - 28.5	50	16	46.5 / 75	18	55	62	5	5 - 10	10	6	8
30.0	29.5 - 30.5	42	16	46.5 / 75	18	57	65	5	5 - 10	10	6	8
33.7	33.2 - 34.2	39	16	46.5 / 75	18	61	70	5	5 - 10	10	6	8
35.0	34.5 - 35.5	37	16	46.5 / 75	18	62	71	5	5 - 10	12	6	8
38.0	37.5 - 38.5	36	16	46.5 / 75	18	65	74	5	5 - 10	12	6	8
40.0	39.5 - 40.5	35	16	46.5 / 75	18	67	76	5	5 - 10	12	6	8
42.4	41.9 - 42.9	33	16	46.5 / 75	18	70	79	5	5 - 10	12	6	8
44.5	44.0 - 45.0	30	16	46.5 / 75	18	72	81	5	5 - 10	12	6	8
48.3	47.8 - 48.8	28	16	46.5 / 75	18	75	86	5	5 - 10	12	6	8
54.0	53.5 - 54.5	24	16	65	24	81	92	5	5 - 15	15	6	8
57.0	56.4 - 57.6	23	16	65	24	84	95	5	5 - 15	15	6	8
60.3	59.7 - 60.9	23	16	65	24	87	98	5	5 - 15	15	6	8
63.0	62.4 - 63.6	23	16	65	24	90	101	5	5 - 15	15	6	8
66.6	64.9 - 67.3	22	16	65	24	94	105	5	5 - 15	15	6	8
70.0	68.9 - 70.7	22	16	65	24	97	109	5	5 - 15	15	6	8
73.0	72.3 - 73.7	21	16	65	24	100	112	5	5 - 15	15	6	8
76.1	75.3 - 76.9	35	16	100	40	110	127	5 - 10	5 - 25	20	8	10
79.5	78.7 - 80.3	32	16	100	40	113	130	5 - 10	5 - 25	20	8	10
84.0	83.2 - 84.8	29	16	100	40	117	135	5 - 10	5 - 25	20	8	10
88.9	88.0 - 89.8	26	16	100	40	122	139	5 - 10	5 - 25	20	8	10
95.0	94.0 - 96.0	24	16	100	40	127	144	5 - 10	5 - 25	25	8	10
98.0	97.0 - 99.0	24	16	100	40	131	148	5 - 10	5 - 25	25	8	10
100.6	99.6 - 101.6	23	16	100	40	134	151	5 - 10	5 - 25	25	8	10
101.6	100.6 - 102.6	23	16	100	40	135	151	5 - 10	5 - 25	25	8	10
104.0	103.0 - 105.0	23	16	100	40	137	153	5 - 10	5 - 25	25	8	10
104.8	103.8 - 105.8	23	16	100	40	138	155	5 - 10	5 - 25	25	8	10
108.0	106.9 - 109.1	22	16	100	40	142	159	5 - 10	5 - 25	25	8	10
114.3	113.2 - 115.4	22	16	100	40	148	165	5 - 10	5 - 25	25	8	10
118.0	116.9 - 119.1	22	16	100	40	152	171	5 - 10	5 - 25	25	8	10
125.0	123.7 - 126.3	21	16	115	53	162	179	5 - 10	5 - 30	40	10	12
127.0	125.7 - 128.3	21	16	115	53	164	181	5 - 10	5 - 30	40	10	12
129.0	127.7 - 130.3	21	16	115	53	166	183	5 - 10	5 - 30	40	10	12
130.2	128.9 - 131.5	21	16	115	53	167	184	5 - 10	5 - 30	40	10	12
133.0	131.7 - 134.3	21	16	115	53	170	187	5 - 10	5 - 30	40	10	12
139.7	138.3 - 141.1	20	16	115	53	176	194	5 - 10	5 - 30	40	10	12
141.3	139.9 - 142.7	20	16	115	53	178	195	5 - 10	5 - 30	40	10	12
144.0	142.6 - 145.4	20	16	115	53	181	188	5 - 10	5 - 30	50	10	12
154.0	152.5 - 155.5	18	16	115	53	191	208	5 - 10	5 - 30	50	10	12
159.0	157.4 - 160.6	18	16	115	53	196	213	5 - 10	5 - 30	50	10	12
165.0	163.4 - 166.6	16	16	115	53	202	219	5 - 10	5 - 30	50	10	12
168.3	166.6 - 170.0	16	16	115	53	205	222	5 - 10	5 - 30	50	10	12

REFER TO MINIMUM WALL THICKNESS (see page 105)

- Follow fitting instructions
- According to DIN 86128
- PN () = working pressure considering the application loads
Test pressure = PN () x 1.5 (for example industry, water supply etc.)
- PN () = nominal pressure, includes four times safety factor (e.g. shipbuilding)
- The pressure values are valid on radial rigid carbon steel pipes under static loads
- Strip inserts are optional accessories (see page 87)
- Additional sealing sleeves and temperature ranges on request

Components / Materials	W1	W2	W4	W5
Casing		AISI 316 L or similar		AISI 316 L or similar
Bolts		AISI 4135		A4 - 80
Bars		AISI 12L14, galvanised		AISI 316 L or similar
Anchoring rings		AISI 301		AISI 301
Strip insert (option)		AISI 316 L or similar / HDPE		AISI 316 L or similar / HDPE

Sealing sleeve EPDM	Temp.: -20°C up to +100°C	Medium: all qualities of water, waste water, air, solids and chemical products
Sealing sleeve NBR	Temp.: -20°C up to +80°C	Medium: water, gas, oil, fuel and other hydrocarbons
Sealing sleeve FPM/FKM	Temp.: -20°C up to +180°C	Medium: ozone, oxygen, acids, gas, oil and fuel (only with strip insert)

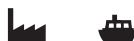
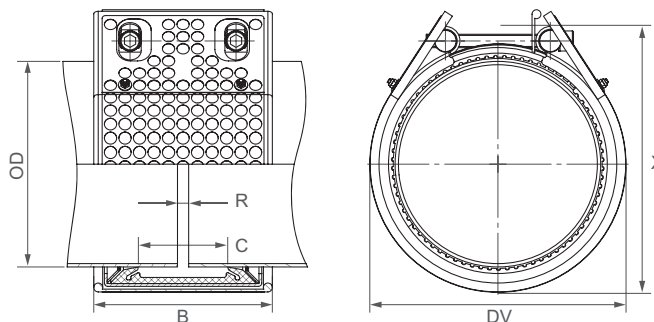

OD [mm]	Clamping range [mm]	PN [bar]	PN [bar]	B [mm]	C [mm]	DV [mm]	X [mm]	R without strip insert [mm]	R with strip insert [mm]	Torque rate [Nm]	Allen head [mm]	Thread M...
180.0	178.0 - 182.0	16	10	158	80	260	238	5 - 10	5 - 35	50	10	12
193.7	192.0 - 195.5	16	10	158	80	275	248	5 - 10	5 - 35	50	10	12
200.0	198.0 - 202.0	15	10	158	80	280	254	5 - 10	5 - 35	50	10	12
204.0	202.0 - 206.0	14	10	158	80	285	258	5 - 10	5 - 35	50	10	12
206.0	204.0 - 208.0	14	5.5	158	80	234	258	5 - 10	5 - 35	50	10	12
219.1	216.9 - 221.3	16	10	142	80	250	274	5 - 10	5 - 30	60	10	12
244.5	242.0 - 247.0	9	5.5	158	80	325	299	5 - 10	5 - 35	50	10	12
250.0	247.5 - 252.5	9	5.5	158	80	330	304	5 - 10	5 - 35	50	10	12
254.0	251.5 - 256.5	9	5.5	158	80	330	308	5 - 10	5 - 35	50	10	12
256.0	253.5 - 258.5	9	5.5	158	80	284	308	5 - 10	5 - 35	50	10	12
267.0	264.5 - 269.5	8	5	158	80	345	321	5 - 10	5 - 35	50	10	12
273.0	270.5 - 275.5	7	4	158	80	350	327	5 - 10	5 - 35	60	10	12
306.0	303.0 - 309.0	6	3	158	80	334	358	5 - 10	5 - 35	60	10	12
323.9	320.5 - 327.0	5	3	158	80	400	378	5 - 10	5 - 35	60	10	12
355.6	352.0 - 359.0	10	2.5	158	67	430	410	5 - 10	5 - 35	90	14	16
406.4	402.5 - 410.5	7	2	158	67	475	460	5 - 10	5 - 35	100	14	16

REFER TO MINIMUM WALL THICKNESS (see page 105)

Remarks:

- Follow fitting instructions
- PN (🏭) = working pressure considering the application loads
Test pressure = PN (🏭) x 1.5 (for example industry, water supply etc.)
PN (🚢) = nominal pressure, includes four times safety factor (e.g. shipbuilding)
- The pressure values are valid on radial rigid carbon steel pipes under static loads
- Strip inserts are optional accessories (see page 87)
- Additional sealing sleeves and temperature ranges on request

EASY & ECONOMIC STRAUB-ECO-GRIP

6
bar

The STRAUB-ECO-GRIP complements the STRAUB range where lower pressures are needed.

STRAUB-ECO-GRIP couplings are used where the loads on the pipe system are low, e.g. service and control lines in the industrial area or applications in plant engineering or process technology.

Due to the small casing width and the one-screw closure, the STRAUB-ECO-GRIP only needs very little space.

The ready to use coupling provides maximum flexibility - on metal and also plastic pipes (PVC, ABS, CPVC).



- Outside diameter: 26.9 up to 168.3 mm
- Temperature: -10°C up to +40°C
- Sealing sleeve: EPDM, NBR



Components / Materials	W1	W2	W4	W5
Casing			AISI 301	
Bolts			A4 - 80	
Bars			AISI 316 L or similar	
Anchoring rings			AISI 301	
Strip insert (option)			AISI 316 L or similar	

Sealing sleeve EPDM	Temp.:	-10°C up to +40°C
	Medium:	all qualities of water, waste water, air, solids and chemical products
Sealing sleeve NBR	Temp.:	-10°C up to +40°C
	Medium:	water, gas, oil, fuel and other hydrocarbons

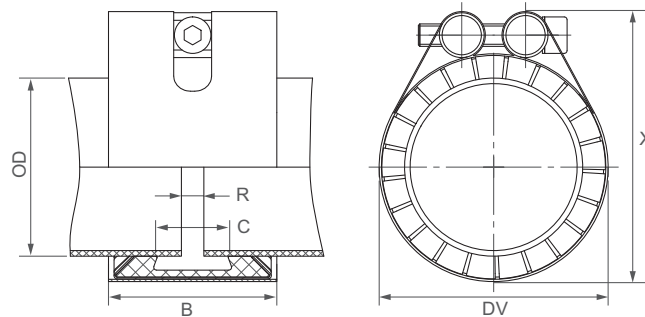

OD [mm]	Clamping range [mm]	PN [bar]	B [mm]	C [mm]	DV [mm]	X [mm]	R without strip insert [mm]	R with strip insert [mm]	Torque rate [Nm]	Allen head [mm]	Thread M...
26.9	26.4 - 27.4	6	45	18	41	54	5	10	10	6	8
30.0	29.5 - 30.5	6	45	18	45	58	5	10	10	6	8
33.7	33.2 - 34.2	6	45	18	48	61	5	10	10	6	8
38.0	37.5 - 38.5	6	45	18	52	65	5	10	10	6	8
42.4	41.9 - 42.9	6	45	18	56	69	5	10	12	6	8
44.5	44.0 - 45.0	6	45	18	59	72	5	10	12	6	8
48.3	47.8 - 48.8	6	45	18	62	75	5	10	15	6	8
57.0	56.4 - 57.6	6	60	26	71	84	5	10	15	6	8
58.0	57.5 - 58.5	6	60	26	73	86	5	10	15	6	8
60.3	59.7 - 60.9	6	60	26	76	89	5	10	15	6	8
63.0	62.2 - 63.8	6	60	26	86	99	5	10	15	6	8
76.1	75.3 - 76.9	6	60	26	92	105	5	10	18	6	8
78.0	77.1 - 78.8	6	60	26	95	108	5	10	18	6	8
83.0	82.1 - 83.8	6	60	26	101	114	5	10	18	6	8
88.9	88.0 - 89.8	6	60	26	108	121	5	10	18	6	8
104.0	103.0 - 105.0	6	60	26	120	133	5	10	18	6	8
108.0	106.9 - 109.1	6	60	26	124	137	5	10	18	6	8
110.0	108.9 - 111.1	6	60	26	126	139	5	10	18	6	8
114.3	113.2 - 115.4	6	60	26	130	143	5	10	18	6	8
129.0	128.0 - 130.0	6	62	26	145	162	5	10	30	6	8
133.0	131.7 - 134.3	6	62	26	149	166	5	10	30	8	10
135.0	133.7 - 136.3	6	62	26	152	169	5	10	30	8	10
139.7	138.3 - 141.1	6	62	26	156	173	5	10	30	8	10
159.0	157.4 - 160.6	6	62	26	177	194	5	10	35	8	10
160.0	158.4 - 161.6	6	62	26	179	196	5	10	35	8	10
168.3	166.6 - 170.0	6	62	26	185	202	5	10	35	8	10

INTERMEDIATE SIZES ON REQUEST
REFER TO MINIMUM WALL THICKNESS (see page 105)

Remarks:

- Follow fitting instructions
- PN = working pressure considering the application loads
 Test pressure = PN x 1.5 (for example industry, water supply etc.)
- The pressure values are valid on radial rigid carbon steel pipes under static loads
- Strip inserts are optional accessories (see page 87)
- Additional dimensions, sealing sleeves and temperature ranges on request

CONNECT UNIVERSALLY WITH **STRAUB-COMBI-GRIP** and **STRAUB-PLAST-GRIP**

STRAUB-COMBI-GRIP
for transitions from
metal to plastic pipes;
STRAUB-PLAST-GRIP
for the connection of
plastic pipes.

The installation and connection of plastic pipes presents new challenges for the contractor. Many connection types are dependent on the weather or temperature or need electrical equipment and special tools for the installation.

Pipes made of all types of plastic can be connected with STRAUB-PLAST-GRIP. In particular, two different plastics can be connected to each other.

In the case of adjustments to or changes of already installed systems, the pipe connection can be easily detached and re-used. The costs/benefits ratio is positively influenced.

STRAUB-COMBI-GRIP and STRAUB-PLAST-GRIP are axial restraint reliable pipe connections that can be used everywhere at any time.



STRAUB-COMBI-GRIP

- Outside diameter: 38.0 up to 355.0 mm
- Temperature: -20°C up to +100°C
- Sealing sleeve: EPDM, NBR



STRAUB-PLAST-GRIP



Connecting plastic pipes (PE/PP) requires the use of stiffening rings

STIFFENING RINGS

Thermoplastic pipes can be deformed under the influence of pressure and heat.

Through the use of STRAUB stiffening rings, a constriction of the plastic pipe ends is prevented.

STRAUB stiffening rings consist of stainless steel DIN 1.4301/AISI 304 and are available in slotted (OD 40 - 315mm) and welded designs (OD 355 - 1600 mm). One of the following may be required:

- Inside diameter
- SDR number
- Wall thickness of the plastic pipe

If the pipes already exhibit constriction due to long storage, we recommend cutting off these constricted sections before fitting the STRAUB stiffening rings. Slotted stiffening rings must be fitted in the direction of the arrow marked and installed flush with the pipe end.

Note:

For plastic pipes in PVC, ABS and CPVC, no stiffening rings are required for media temperatures under 40°C.



Table for choosing the STRAUB-PLAST-GRIP stiffening ring

SDR	41	33 / 32.25	26	17.6	17	11	7.4 / 7.25
Serie-Nr.	S 20	S 16 / S 15.625	S 12.5	S 8.3	S 8	S 5	S 3.2 / S 3.125
Norm	DIN 8074	DIN 8074	DIN 8074	DIN 8074	DIN 8074	DIN 8074	DIN 8074
Pipe OD	Pipe ID	Pipe ID	Pipe ID	Pipe ID	Pipe ID	Pipe ID	Pipe ID
OD [mm]	[mm]	[mm]	[mm]	[mm]	[mm]	[mm]	[mm]
40	-	-	36.4	35.4	35.2	32.6	29
50	-	46.4	46.0	44.2	44.0	40.8	36.2
63	59.4	59.0	58.0	55.8	55.4	51.4	45.8
75	71.2	70.4	69.2	66.4	66.0	61.4	54.4
90	85.6	84.4	83.0	79.8	79.2	73.6	65.4
110	104.6	103.2	101.6	97.4	96.8	90.0	79.8
125	118.8	117.2	115.4	110.8	110.2	102.2	90.8
140	133.0	131.4	129.2	124.0	123.4	114.6	101.6
160	152.0	150.2	147.6	141.8	141.0	130.8	116.2
180	171.2	169.0	166.2	159.6	158.6	147.2	130.8
200	190.2	187.6	184.6	177.2	176.2	163.6	145.2
225	214.0	211.2	207.8	199.4	198.2	184.0	163.4
250	237.6	234.6	230.8	221.6	220.4	204.6	181.6
280	266.2	262.8	258.6	248.2	246.8	229.2	203.4
315	299.6	295.6	290.8	279.2	277.6	257.8	228.8

Remarks:

- Choosing stiffening rings owing to measurements on pipes only conditionally possible
- Valid only to soft thermoplastic pipes f.e. PE, PP, etc.
- Stiffening rings are optional accessories and has to be ordered separately.

Components / Materials	W1	W2	W4	W5
Casing		AISI 316 L		AISI 316 L or similar
Bolts		AISI 4135		A4 - 80
Bars		AISI 12L14, galvanised		AISI 316 L or similar
Anchoring rings		AISI A106, galvanised		AISI 301 / 304
Strip insert (option)		AISI 316 L or similar / PVDF		AISI 316 L or similar / PVDF

Sealing sleeve EPDM	Temp.: -20°C up to +100°C	Medium: all qualities of water, waste water, air, solids and chemical products
Sealing sleeve NBR	Temp.: -20°C up to +80°C	Medium: water, gas, oil, fuel and other hydrocarbons

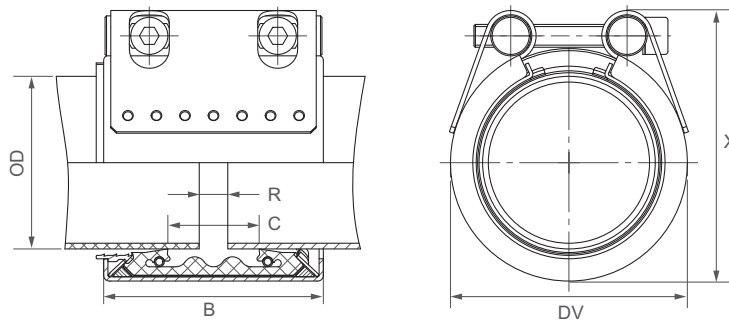

OD [mm]	Clamping range [mm]		PN [bar]	B [mm]	C [mm]	DV [mm]	X [mm]	R without strip insert [mm]	R with strip insert [mm]	Torque rate [Nm]	Allen head [mm]	Thread M...
	Plastic	Metal										
40.0/38.0	39.0 - 40.5	37.5 - 39.0	16	61	19	60	73	5	5 - 10	15	6	8
40.0/42.4	39.0 - 40.5	42.0 - 43.5	16	61	20	63	76	5	5 - 10	15	6	8
50.0/48.3	49.0 - 50.5	47.8 - 49.0	16	61	26	70	83	5	5 - 10	15	6	8
60.0/60.3	59.0 - 61.0	59.7 - 61.0	16	76	32	85	98	5 - 10	5 - 25	20	6	8
63.0/60.3	62.0 - 64.0	59.7 - 61.0	16	76	32	85	98	5 - 10	5 - 25	20	6	8
75.0/76.1	74.0 - 76.0	75.0 - 77.5	16	94	39	100	117	5 - 10	5 - 25	30	8	10
90.0/88.9	89.0 - 91.0	87.0 - 90.0	16	94	39	118	123	5 - 10	5 - 25	30	8	10
110.0/108.0	109.0 - 111.0	106.5 - 110.5	16	94	39	135	151	5 - 10	5 - 25	30	8	10
110.0/114.3	109.0 - 111.0	112.0 - 116.0	16	97	45	139	157	5 - 10	5 - 25	30	8	10
114.3/114.3	113.0 - 115.0	112.0 - 116.0	16	94	39	140	157	5 - 10	5 - 25	30	8	10
140.0/139.7	139.0 - 142.0	137.5 - 141.0	16	109	43	168	191	5 - 15	5 - 30	60	10	12
160.0/159.0	159.0 - 162.0	157.0 - 160.5	16 / 10 ¹	109	43	188	210	5 - 15	5 - 30	60	10	12
160.0/168.3 ¹	159.0 - 162.0	166.6 - 170.0	16	110	54	192	222	5 - 10	5 - 30	20	10	12
200.0/206.0	198.0 - 202.0	204.0 - 208.0	16	141	80	227	246	5 - 15	5 - 35	60	10	12
225.0/219.1	223.0 - 227.0	216.9 - 221.3	10	141	80	252	271	5 - 15	5 - 35	60	10	12
225.0/229.0	223.0 - 227.0	227.0 - 231.0	10	141	80	252	271	5 - 15	5 - 35	60	10	12
250.0/256.0	248.0 - 252.0	253.5 - 258.5	10	141	80	277	296	5 - 15	5 - 35	60	10	12
280.0/273.0	278.0 - 282.0	271.0 - 275.0	10	141	80	307	330	5 - 15	5 - 35	100	14	16
315.0/323.9	313.0 - 317.0	320.5 - 327.0	10	141	80	342	365	5 - 15	5 - 35	120	14	16
355.0/355.6	353.0 - 357.0	352.0 - 359.0	6	141	80	382	405	5 - 15	5 - 35	150	14	16

Remarks:

- Follow fitting instructions
- PN = working pressure considering the application loads
Test pressure = PN x 1.5 (for example industry, water supply etc.)
- For the installation of pipes made of HDPE and PP, STRAUB stiffening rings are required (see page 29)
- Strip inserts are optional accessories (see page 87)
- Additional sealing sleeves and temperature ranges on request

¹ 160.0/159.0 mm: version in W2 ⇒ PN 16 bar
version in W5 ⇒ PN 10 bar
160.0/168.3 mm: only available in W5

Components / Materials	W1	W2	W4	W5
Casing		AISI 316 L		AISI 316 L or similar
Bolts		AISI 4135		A4 - 80
Bars		AISI 12L14, galvanised		AISI 316 L or similar
Anchoring rings		AISI A106, galvanised		AISI 301 / 304
Strip insert (option)		AISI 316 L or similar / PVDF		AISI 316 L or similar / PVDF

Sealing sleeve EPDM	Temp.: -20°C up to +100°C	Medium: all qualities of water, waste water, air, solids and chemical products
Sealing sleeve NBR	Temp.: -20°C up to +80°C	Medium: water, gas, oil, fuel and other hydrocarbons

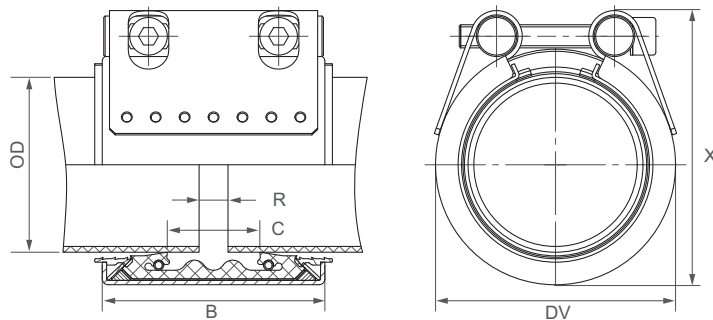

OD [mm]	Clamping range [mm]	PN [bar]	B [mm]	C [mm]	DV [mm]	X [mm]	R without strip insert [mm]	R with strip insert [mm]	Torque rate [Nm]	Allen head [mm]	Thread M...
40.0	39.0 - 40.5	16	61	19	60	73	5	5 - 15	15	6	8
50.0	49.0 - 50.5	16	61	26	70	83	5	5 - 15	15	6	8
63.0	62.0 - 64.0	16	76	32	85	98	5 - 10	5 - 20	20	6	8
75.0	74.0 - 76.0	16	94	39	99	117	5 - 10	5 - 25	30	8	10
90.0	89.0 - 91.0	16	94	39	118	123	5 - 10	5 - 25	30	8	10
110.0	109.0 - 111.0	16	94	39	135	151	5 - 10	5 - 25	30	8	10
114.3	113.0 - 115.0	16	94	39	139	157	5 - 10	5 - 30	30	10	12
125.0	124.0 - 126.0	16	94	43	152	174	5 - 15	5 - 30	60	10	12
140.0	139.0 - 142.0	16	108	43	168	191	5 - 15	5 - 30	60	10	12
160.0	159.0 - 162.0	16 / 10 ¹	109	43	188	210	5 - 15	5 - 25	60	10	12
180.0	178.0 - 182.0	16	141	80	207	226	5 - 15	5 - 35	60	10	12
200.0	198.0 - 202.0	16	141	80	227	246	5 - 15	5 - 35	60	10	12
225.0	223.0 - 227.0	10	141	80	252	271	5 - 15	5 - 35	60	10	12
250.0	248.0 - 252.0	10	141	80	277	296	5 - 15	5 - 35	60	10	12
280.0	278.0 - 282.0	10	141	80	307	330	5 - 15	5 - 35	100	14	16
315.0	313.0 - 317.0	10	141	80	342	365	5 - 15	5 - 35	120	14	16
355.0	353.0 - 357.0	6	141	80	382	405	5 - 15	5 - 35	150	14	16

Remarks:

- Follow fitting instructions
- PN = working pressure considering the application loads
Test pressure = PN x 1.5 (for example industry, water supply etc.)
- For the installation of pipes of pipes made of HDPE and PP, STRAUB stiffening rings are required (see page 29)
- Strip inserts are optional accessories (see page 87)
- Additional sealing sleeves and temperature ranges on request







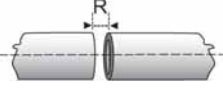
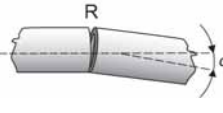

¹ 160.0/159.0 mm: version in W2 ⇒ PN 16 bar
version in W5 ⇒ PN 10 bar

STRAUB-GRIP

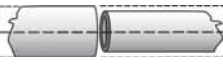
FITTING INSTRUCTION

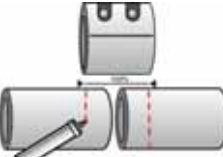
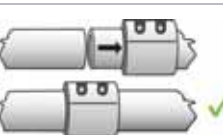

Please note complete fitting instructions for each type of coupling!

Installation conditions		<p>R = Pipe gap</p> <p>A space between pipe ends can arise through misalignment, inaccurate assembly or changes in length. STRAUB couplings can bridge spaces between pipe ends.</p> <ul style="list-style-type: none"> 5 - 10 mm without strip insert (depending on pipe OD, please observe the coupling label!) 5 - 35 mm with strip insert (depending on pipe OD, please observe techn. data sheet!) <p>Strip inserts are used in case of: large distance between pipe ends, swelling due to aggressive liquids, vacuum, under outside pressure, high temperature. Strip inserts are extras and must be ordered separately.</p>
		<p>Angular deflection α</p> <p>< \varnothing 60.3 mm \Rightarrow 5° > \varnothing 76.1 mm \Rightarrow 4° \Rightarrow See distance between pipe ends > \varnothing 219.1 mm \Rightarrow 2° > \varnothing 609.6 mm \Rightarrow 1°</p>
		<p>Linear misalignment</p> <p>1% of outer diameter (max. 3 mm) is admissible</p>
		<p>Outside diameter difference</p> <p>< \varnothing 100 mm \Rightarrow 2 mm > \varnothing 100 mm \Rightarrow 2 % > \varnothing 300 mm \Rightarrow 6 mm</p>
		<p>Min. pipe wall thickness</p> <p>Please refer to the min. pipe wall thickness on page 105.</p> <p>Test pressure</p> <p>The pipe installation must be checked as follows before commissioning: 1,5 x working pressure</p> <p>Do not work above limits or cummulate. Limits for static loads and radial rigid pipes only. For dynamic forces like pressure surges and thrust apply safety factor (contact factory).</p>
Installation		<p>De-burr and remove sharp edges from pipe ends. Clean the pipe surface. No dirt under sealing lips.</p>
		<p>Center coupling over gap between pipe ends and mark the coupling position; \Rightarrow min. pipe gap 5 mm</p>
		<p>Strip inserts are used in case of: large distance between pipe ends, swelling due to aggressive liquids, vacuum, under outside pressure, high temperature. Strip inserts are extras and must be ordered separately.</p>
		<p>Tighten the locking bolts with a torque wrench to the final prescribed torque rate engraved on the pipe joints outer surface. The torque wrench must be set to the value accordingly. Repeat the tightening sequence until a quarter turn or less is needed to reach the required torque.</p>
		<p>Straub couplings must be torqued to the specified value as printed on each coupling, failure to do so can result in injury or death. In case of leakage clean pipe and sealing lips surface before installing pipe joint again. Do not use the power wrench for stainless steel screws.</p>
	<p>Additional corrosion protection</p> <p>If risk of corrosion exists, for long term pipe joint protection use shrink sleeves or protection tapes.</p>	

THE PE COMPLETE KIT

STRAUB-PLAST-PRO

An axially restrained jointing system allowing a quick and simple installation of pressure pipes made of polyethylene (PE).

STRAUB-PLAST-PRO offers an alternative to traditional jointing methods of PE used in water, waste water, industrial plants and maintenance applications. The complete product range is available for PE pipes in dimension SDR 11 (63.0 - 180.0 mm; PN 16) and SDR 17 (125.0 - 355.0 mm; PN 10).

The full product range offers the great advantage that pipes can easily be connected without the need of external power supply and pipe end preparation, even under demanding external weather conditions.

The pipes made of PE 80 or PE 100 are connected with a combination of liner inserts and external shells. The jointing concept allows the product to be assembled easily and is difficult to get wrong.

PE pipes with added protective coatings are available in a variety of designs such as PE pipes with a diffusionproof aluminium foil barrier layer that are commonly preferred to be laid in contaminated soil sites. Thus, pollutants are prevented from entering into the pipe and the medium is prevented from getting into ground soil.

STRAUB-PLAST-PRO also connects barrier layer pipes easily and safely without any pipe end preparation. Before assembly the pipe outside diameter should be confirmed and checked that it fits into the working range of the individual shell.



Example for ordering | DIN EN:
STRAUB-PLAST-PRO L d90.0, SDR 11

Example for ordering | multilayer:
STRAUB-PLAST-PRO FA d63/DN 50, SDR 11; OD 64-66mm

The product range of STRAUB-PLAST-PRO is combined from different liner inserts and external shells. By this versatile formed-parts-program PE-pipes can be connected easily and fast in every situation.



STRAUB-PLAST-PRO L
Coupler



STRAUB-PLAST-PRO LR
Repair-Coupler
(repairs up to 100 mm)



STRAUB-PLAST-PRO R
Reducer



STRAUB-PLAST-PRO B90
Elbow 90°



STRAUB-PLAST-PRO has been successfully tested according to the **British Standard WIS 4-24-01** and fulfil the requirements to:

- German Standard DVGW-VP609
- European Standard EN 1254-3

STRAUB-PLAST-PRO B45
Elbow 45°



STRAUB-PLAST-PRO T
Equal Tee



STRAUB-PLAST-PRO TFA
Flanged Branch Tee ²



STRAUB-PLAST-PRO FB90
Duck Foot Bend 90° ²



STRAUB-PLAST-PRO FA
Flange Adapter ²
(loose flange ring is included)



² flange bolt set is not supplied (DIN EN 1092-1)

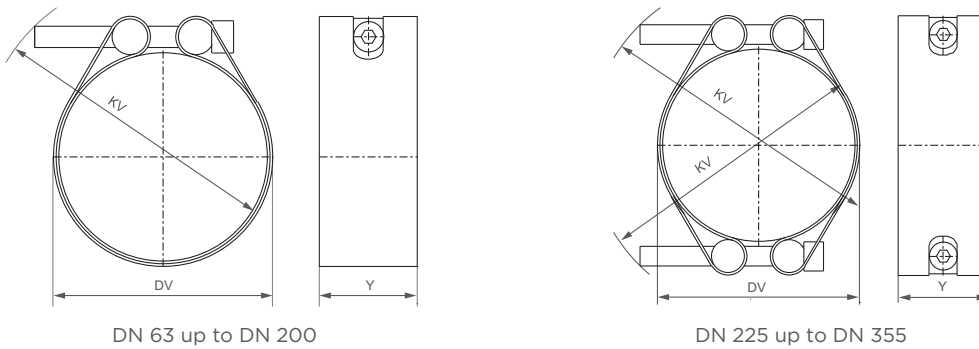

DN	DV braced		KV braced		Y [mm]	Allen head [mm]	Thread M..	Torque rate [Nm]
	DIN 4 [mm]	multilayer [mm]	DIN 4 [mm]	multilayer [mm]				
63	65	67	95	95	47.5	10	12	50
75	79	82 ³	106	107	47.5	10	12	55
90	94	97	120	121	47.5	10	12	60
110	113	117	139	140	55	10	12	60
125	129	132	155	156	55	10 / 14 ⁵	12 / 16 ⁵	60 / 120 ⁵
140	144	147 ³	170	170	55	14	16	130
160	165	168	188	189	55	14	16	150
180	184	188	216	217	55	14	16	160
200	204	208 ³	235	236	55	14	16	180
225	227	230	258	260	55	14	16	160
250	251	255	282	285	55	14	16	160
280	282	285	311	313	55	14	16	160
315	318	321	355	357	60 / 70	17	20	280
355	359	362	394	397	60 / 70	17	20	300

Pipe dimensions and tolerances

Our complete systems are designed for the pipe dimensions according to EN 12201-2:2003 listed below. Multilayer pipes with different outer diameter than DIN EN 12201-2 are available in a variety of designs. These are not standardised and therefore outside diameters and materials used may vary to large extent.

⇒ Due to the additional layers OD's and material of the additive layer may vary (consultation with the producer is necessary, if there is a metal layer integrated); Please note the following pipe dimensions and tolerances.

SDR 11

DN	OD min		OD max		Wall thickness min		Wall thickness max		ID ⁶ [mm]
	DIN 4 [mm]	multilayer [mm]	DIN 4 [mm]	multilayer [mm]	DIN 4 [mm]	multilayer [mm]	DIN 4 [mm]	multilayer [mm]	
63	63.0	64.0	63.4	65.7	5.8	6.5	6.5	7.6	51
75	75.0	77.0 ³	75.5	79.0	6.8	7.8	7.6	9.1	61
90	90.0	92.0	90.6	94.0	8.2	9.3	9.2	10.7	73
110	110.0	112.0	110.7	114.0	10.0	11.1	11.1	12.7	89
125	125.0	127.0	125.8	129.0	11.4	12.5	12.7	14.2	101
140	140.0	143.0	140.9	145.0	12.7	14.0	14.1	15.9	113
160	160.0	163.0	161.0	166.0	14.6	15.8	16.2	18.0	129
180	180.0	183.0	181.1	186.0	16.4	17.6	18.2	20.0	145

SDR 17

DN	OD min		OD max		Wall thickness min		Wall thickness max		ID ⁶ [mm]
	DIN 4 [mm]	multilayer [mm]	DIN 4 [mm]	multilayer [mm]	DIN 4 [mm]	multilayer [mm]	DIN 4 [mm]	multilayer [mm]	
90	90.0	92.0	90.6	94.0	5.3	5.4	6.0	6.5	79
110	110.0	112.0	110.7	114.0	6.5	7.5	7.8	8.6	97
125	125.0	127.0	125.8	129.0	7.4	8.5	8.3	9.8	110
140	140.0	143.0 ³	140.9	145.0	8.3	9.4	9.3	11.1	123
160	160.0	163.0	161.0	166.0	9.5	10.7	10.6	12.4	140
180	180.0	183.0	181.1	186.0	10.7	11.9	11.9	13.7	158
200	200.0	203.0 ³	201.2	206.0	11.9	13.1	13.2	15.0	176
225	225.0	225.0	226.4	230.0	13.4	14.6	14.9	16.6	197
250	250.0	250.0	251.5	255.0	14.8	16.0	16.4	18.3	220
280	280.0	280.0	281.7	286.0	16.6	17.8	18.4	20.1	246
315	315.0	315.0	316.9	321.0	18.7	19.9	20.7	22.4	277
355	355.0	355.0	357.2	361.0	21.1	22.3	23.4	25.1	312

³ not available from our stock
⁴ DIN ⇒ pipe dimensions according to EN 12201-2

⁵ bolt M16 for SDR 11
⁶ ID = average pipe inside diameter

Components	Materials
Shells	AISI 316 L or similar
Bolts	A4 - 80
Bars	AISI 316 L
Liner insert	Carbon steel, Rilsan coated (W270, NSF61, WRAS)
Medium	all qualities of water
Temperature	-5°C up to 40°C ⁷

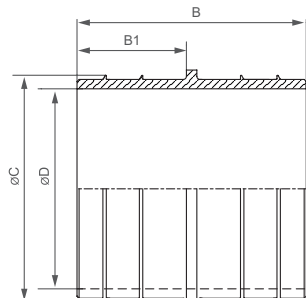

up to 110 mm: for PN 16 pipes ⁷
 from 125 mm: for PN 16 and PN 10 pipes ⁷
 > 180 mm: for PN 10 pipes ⁷

SDR 11

OD [mm]	DIN ⁴	Article multilayer	B [mm]	B1 [mm]	C [mm]	D [mm]	Weight [kg]
63.0	870070	870000	95	45.0	49.5	41.0	1.6
75.0	870075	870005 ³	95	45.0	59.5	50.5	1.8
90.0	870080	870010	95	45.0	71.0	62.0	2.0
110.0	870085	870015	110	52.5	87.5	76.0	2.6
125.0	870089	870019	110	52.5	99.5	86.5	3.1
140.0	870094	870024 ³	110	52.5	111.5	97.5	4.0
160.0	870099	870029	110	52.5	127.5	113.5	4.4
180.0	870104	870034	110	52.5	143.5	126.5	4.8

SDR 17

OD [mm]	DIN ⁴	Article multilayer	B [mm]	B1 [mm]	C [mm]	D [mm]	Weight [kg]
90.0	870081	870011	95	45.0	77.0	66.8	2.1
110.0	870086	870016	110	52.5	94.5	82.3	2.7
125.0	870090	870020	110	52.5	108.0	95.0	3.0
140.0	870095	870025 ³	110	52.5	121.0	107.0	3.8
160.0	870100	870030	110	52.5	138.5	124.5	4.3
180.0	870105	870035	110	52.5	156.0	139.0	5.1
200.0	870110	870040 ³	110	52.5	173.5	154.5	5.5
225.0	870045	870045	110	52.5	195.0	173.0	9.1
250.0	870050	870050	110	52.5	217.0	193.0	10.2
280.0	870055	870055	110	52.5	243.0	217.0	11.9
315.0	870060	870060	130	62.5	273.0	243.0	19.6
355.0	870065	870065	130	62.5	308.0	274.0	23.2

Remarks:

- Test pressure at 20°C = 1.5 x PN
- Higher pressure rates on request
- For protecting pipes, please specify inside and outside diameters
- Pipe diameter range and tolerances ⇨ page 36
- Listed weight corresponds to the total product weight (liner insert and shells)

³ not available from our stock

⁴ DIN ⇨ pipe dimensions according to EN 12201-2

⁷ for permanent temperatures above 20°C, please note the pressure specifications for PE pipes according to DIN 8074

Components	Materials
Shells	AISI 316 L or similar
Bolts	A4 - 80
Bars	AISI 316 L
Liner insert	Carbon steel, Rilsan coated (W270, NSF61, WRAS)
Medium	all qualities of water
Temperature	-5°C up to 40°C ⁷

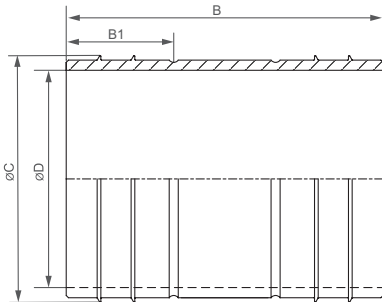

up to 110 mm: for PN 16 pipes ⁷
 from 125 mm: for PN 16 and PN 10 pipes ⁷

SDR 11							
OD [mm]	DIN ⁴	Article multilayer	B [mm]	B1 [mm]	C [mm]	D [mm]	Weight [kg]
63.0	871114	871100	195	47.5	49.5	40.0	1.9
75.0	871115	871101	195	47.5	59.5	49.5	2.2
90.0	871116	871102	195	47.5	71.0	61.0	2.6
110.0	871117	871103	210	55.0	87.5	75.0	3.0
125.0	871123	871127	210	55.0	99.5	85.5	4.0
140.0	871124	871128	210	55.0	111.5	97.5	5.2
160.0	871125	871129	210	55.0	127.5	113.5	5.8
180.0	871126	871130	210	55.0	143.5	126.5	6.7

SDR 17							
OD [mm]	DIN ⁴	Article multilayer	B [mm]	B1 [mm]	C [mm]	D [mm]	Weight [kg]
90.0	871133	871131	195	47.5	77.0	66.8	2.7
110.0	871134	871132	210	55.0	94.5	82.3	3.1
125.0	871118	871104	210	55.0	108.0	94.0	4.4
140.0	871119	871105 ³	210	55.0	121.0	107.0	5.4
160.0	871120	871106	210	55.0	138.5	124.5	6.1
180.0	871121	871107	210	55.0	156.0	139.0	7.1

Remarks:

- Before installing the repair coupler, expose 100 mm clearance between pipe ends
- Other repair-lengths and higher pressure rates on request
- Test pressure at 20°C = 1.5 x PN
- For protecting pipes, please specify inside and outside diameters
- Pipe diameter range and tolerances ⇒ page 36
- Listed weight corresponds to the total product weight (liner insert and shells)

³ not available from our stock

⁴ DIN ⇒ pipe dimensions according to EN 12201-2

⁷ for permanent temperatures above 20°C, please note the pressure specifications for PE pipes according to DIN 8074

⁸ the O-ring prevents the liner from falling into the plastic pipe; O-ring has no sealing function

Components	Materials
Shells	AISI 316 L or similar
Bolts	A4 - 80
Bars	AISI 316 L
Liner insert	Carbon steel, Rilsan coated (W270, NSF61, WRAS)
Medium	all qualities of water
Temperature	-5°C up to 40°C ⁷

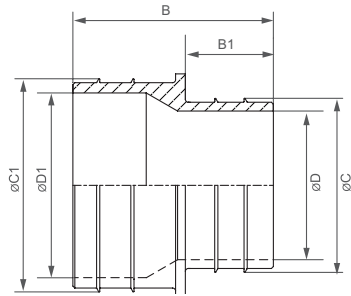

up to 110 mm: for PN 16 pipes ⁷
 from 125 mm: for PN 10 pipes ⁷

SDR 11

OD [mm]	Article DIN ⁴	Article multilayer	B [mm]	B1 [mm]	C [mm]	C1 [mm]	D [mm]	D1 [mm]	Weight [kg]
90.0x63.0	870235	870155	95.0	45.0	49.5	71.0	41.0	62.0	2.0
110.0x90.0	870240	870160	102.5	52.5/45.0	71.0	87.5	62.0	76.0	2.5
125.0x110.0	870245	870165	110.0	52.5	87.5	99.5	76.0	86.5	3.3
160.0x110.0	870260	870176	110.0	52.5	87.5	127.5	76.0	113.5	5.0
160.0x125.0	870270	870180	110.0	52.5	99.5	127.5	86.5	113.5	4.8
180.0x160.0	870280	870189	110.0	52.5	127.5	143.5	113.5	126.5	5.4

SDR 17

OD [mm]	Article DIN ⁴	Article multilayer	B [mm]	B1 [mm]	C [mm]	C1 [mm]	D [mm]	D1 [mm]	Weight [kg]
90.0x63.0	870236	870156	95.0	45.0	49.5	77.0	41.0	66.8	2.2
110.0x90.0	870241	870161	102.5	45.0	77.0	94.5	66.8	82.3	2.6
125.0x110.0 ⁹	870250	870170	110.0	52.5	87.5	108.0	76.0	95.0	3.2
125.0x110.0	870251	870171	110.0	52.5	94.5	138.5	82.3	95.0	3.2
160.0x110.0 ⁹	870185	870178	110.0	52.5	87.5	138.5	76.0	124.5	5.4
160.0x125.0	870195	870182	110.0	52.5	108.0	138.5	95.0	124.5	5.8
180.0x125.0	870205	870190	110.0	52.5	108.0	156.0	95.0	139.0	6.2

Remarks:

- Test pressure at 20°C = 1.5 x PN
- Higher pressure ratings and additional dimensions are available on request
- For protecting pipes, please specify inside and outside diameters
- Pipe diameter range and tolerances ⇨ page 36
- Listed weight corresponds to the total product weight (liner insert and shells)

⁴ DIN ⇨ pipe dimensions according to EN 12201-2

⁷ for permanent temperatures above 20°C, please note the pressure specifications for PE pipes according to DIN 8074

⁹ OD 110 mm in SDR 11

Components	Materials
Shells	AISI 316 L or similar
Bolts	A4 - 80
Bars	AISI 316 L
Liner insert	Carbon steel, Rilsan coated (W270, NSF61, WRAS)
Medium	all qualities of water
Temperature	-5°C up to 40°C ⁷

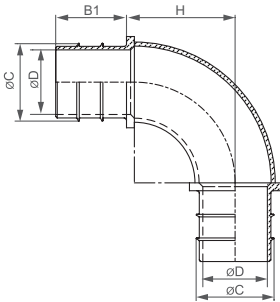

up to 110 mm: for PN 16 pipes ⁷
 from 125 mm: for PN 16 and PN 10 pipes ⁷
 > 180 mm: for PN 10 pipes ⁷

SDR 11

OD [mm]	DIN ⁴	Article multilayer	B1 [mm]	C [mm]	D [mm]	H [mm]	Weight [kg]
63.0	870520	870450	45.0	49.5	41.0	69.0	2.0
75.0	870525	870455 ³	45.0	59.5	50.5	77.0	2.3
90.0	870530	870460	45.0	71.0	62.0	97.0	3.2
110.0	870535	870465	52.5	87.5	76.0	122.0	3.7
125.0	870539	870469	52.5	99.5	86.5	138.0	6.1
140.0	870544	870474 ³	52.5	111.5	97.5	147.0	6.9
160.0	870549	870479	52.5	127.5	113.5	180.0	9.3
180.0	870554	870484	52.5	143.5	126.5	200.0	10.6

SDR 17

OD [mm]	DIN ⁴	Article multilayer	B1 [mm]	C [mm]	D [mm]	H [mm]	Weight [kg]
90.0	870531	870461	45.0	77.0	66.8	100.0	3.3
110.0	870536	870466	52.5	94.5	82.3	122.0	3.8
125.0	870540	870470	52.5	108.0	95.0	147.0	6.0
140.0	870545	870475	52.5	121.0	107.0	157.0	7.1
160.0	870550	870480	52.5	138.5	124.5	195.0	8.3
180.0	870555	870485	52.5	156.0	139.0	226.0	10.8
225.0	870495 ³	870495 ³	52.5	195.0	173.0	280.0	19.6
250.0	870500 ³	870500 ³	52.5	217.0	193.0	325.0	26.0
280.0	870505 ³	870505 ³	52.5	243.0	217.0	398.0	37.0
315.0	870510 ³	870510 ³	52.5	273.0	243.0	401.0	44.5
355.0	870515 ³	870515 ³	52.5	308.0	274.0	477.0	63.2

Remarks:

- Test pressure at 20°C = 1.5 x PN
- Higher pressure ratings and additional dimensions are available on request
- For protecting pipes, please specify inside and outside diameters
- Pipe diameter range and tolerances ⇨ page 36
- Listed weight corresponds to the total product weight (liner insert and shells)

³ not available from our stock

⁴ DIN ⇨ pipe dimensions according to EN 12201-2

⁷ for permanent temperatures above 20°C, please note the pressure specifications for PE pipes according to DIN 8074

Components	Materials
Shells	AISI 316 L or similar
Bolts	A4 - 80
Bars	AISI 316 L
Liner insert	Carbon steel, Rilsan coated (W270, NSF61, WRAS)
Medium	all qualities of water
Temperature	-5°C up to 40°C ⁷

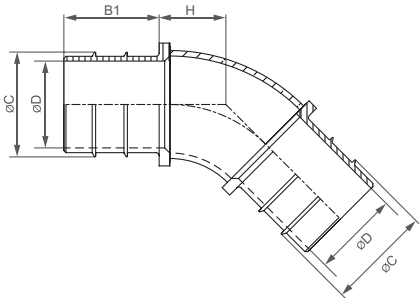

up to 110 mm: for PN 16 pipes ⁷
 from 125 mm: for PN 16 and PN 10 pipes ⁷
 > 180 mm: for PN 10 pipes ⁷

SDR 11							
OD [mm]	DIN ⁴	Article multilayer	B1 [mm]	C [mm]	D [mm]	H [mm]	Weight [kg]
63.0	870642	870600	45.0	49.5	41.0	32.0	1.8
75.0	870645	870603 ³	45.0	59.5	50.5	35.0	2.0
90.0	870648	870606	45.0	71.0	62.0	43.0	2.3
110.0	870651	870609	52.5	87.5	76.0	53.0	3.1
125.0	870653	870611	52.5	99.5	86.5	60.0	4.9
140.0	870656	870614 ³	52.5	111.5	97.5	64.0	5.2
160.0	870659	870617	52.5	127.5	113.5	77.5	7.4
180.0	870662	870620	52.5	143.5	126.5	89.0	8.1

SDR 17							
OD [mm]	DIN ⁴	Article multilayer	B1 [mm]	C [mm]	D [mm]	H [mm]	Weight [kg]
90.0	870649	870607	45.0	77.0	66.8	44.4	2.4
110.0	870652	870610	52.5	94.5	82.3	53.5	3.2
125.0	870654	870612	52.5	108.0	95.0	64.0	4.9
140.0	870657	870615 ³	52.5	121.0	107.0	68.0	6.5
160.0	870660	870618	52.5	138.5	124.5	84.0	7.7
180.0	870663	870621	52.5	156.0	139.0	94.0	8.2
225.0	870627 ³	870627 ³	52.5	195.0	173.0	117.0	14.9
250.0	870630 ³	870630 ³	52.5	217.0	193.0	131.0	18.5
280.0	870633 ³	870633 ³	52.5	243.0	217.0	162.0	25.0
315.0	870636 ³	870636 ³	52.5	273.0	243.0	163.0	32.0
355.0	870639 ³	870639 ³	52.5	308.0	274.0	194.0	43.2

Remarks:

- Test pressure at 20°C = 1.5 x PN
- Higher pressure ratings and additional dimensions are available on request
- For protecting pipes, please specify inside and outside diameters
- Pipe diameter range and tolerances ⇨ page 36
- Listed weight corresponds to the total product weight (liner insert and shells)

³ not available from our stock

⁴ DIN ⇨ pipe dimensions according to EN 12201-2

⁷ for permanent temperatures above 20°C, please note the pressure specifications for PE pipes according to DIN 8074

Components	Materials
Shells	AISI 316 L or similar
Bolts	A4 - 80
Bars	AISI 316 L
Liner insert	Carbon steel, Rilsan coated (W270, NSF61, WRAS)
Medium	all qualities of water
Temperature	-5°C up to 40°C ⁷

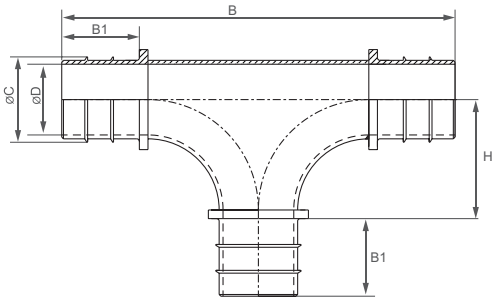

up to 110 mm: for PN 16 pipes ⁷
 from 125 mm: for PN 16 and PN 10 pipes ⁷
 > 180 mm: for PN 10 pipes ⁷

SDR 11

OD [mm]	DIN ⁴	Article multilayer	B [mm]	B1 [mm]	C [mm]	D [mm]	H [mm]	Weight [kg]
63.0	870370	870300	214.0	45.0	49.5	41.0	62.0	3.0
75.0	870375	870305 ³	228.0	45.0	59.5	50.5	69.0	4.0
90.0	870380	870310	252.0	45.0	71.0	62.0	81.0	5.3
110.0	870385	870315	287.0	52.5	87.5	76.0	91.0	7.4
125.0	870389	870319	315.0	52.5	99.5	86.5	105.0	7.5
140.0	870394	870324 ³	315.0	52.5	111.5	97.5	105.0	8.2
160.0	870399	870329	355.0	52.5	127.5	113.5	125.0	11.6
180.0	870404	870334	363.0	52.5	143.5	126.5	129.0	12.2

SDR 17

OD [mm]	DIN ⁴	Article multilayer	B [mm]	B1 [mm]	C [mm]	D [mm]	H [mm]	Weight [kg]
90.0	870381	870311	252.0	45.0	77.0	66.8	81.0	5.4
110.0	870386	870316	287.0	52.5	94.5	82.3	91.0	7.5
125.0	870390	870320	325.0	52.5	108.0	95.0	110.0	8.9
140.0	870395	870325 ³	325.0	52.5	121.0	107.0	110.0	12.5
160.0	870400	870330	363.0	52.5	138.5	124.5	129.0	16.1
180.0	870405	870335	401.0	52.5	156.0	139.0	148.0	19.0
225.0	870345 ³	870345 ³	401.0	52.5	195.0	173.0	148.0	20.1
250.0	870350 ³	870350 ³	471.0	52.5	217.0	193.0	183.0	24.5
280.0	870355 ³	870355 ³	471.0	52.5	243.0	217.0	183.0	28.6
315.0	870360 ³	870360 ³	547.0	52.5	273.0	243.0	221.0	44.4
355.0	870365 ³	870365 ³	623.0	52.5	308.0	274.0	259.0	53.8

Remarks:

- Test pressure at 20°C = 1.5 x PN
- Higher pressure ratings and additional dimensions are available on request
- For protecting pipes, please specify inside and outside diameters
- Pipe diameter range and tolerances ⇨ page 36
- Listed weight corresponds to the total product weight (liner insert and shells)

³ not available from our stock

⁴ DIN ⇨ pipe dimensions according to EN 12201-2

⁷ for permanent temperatures above 20°C, please note the pressure specifications for PE pipes according to DIN 8074

Components	Materials
Shells	AISI 316 L or similar
Bolts	A4 - 80
Bars	AISI 316 L
Liner insert	Carbon steel, Rilsan coated (W270, NSF61, WRAS)
Medium	all qualities of water
Temperature	-5°C up to 40°C ⁷

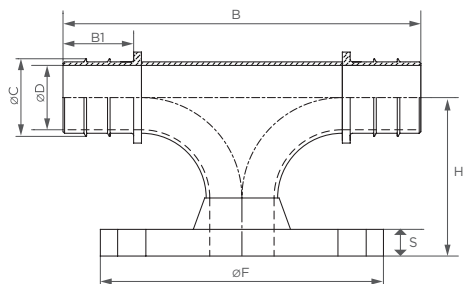

up to 110 mm: for PN 16 pipes ⁷
 from 125 mm: for PN 10 pipes ⁷

SDR 11

OD [mm]	Article DIN ⁴	Article multilayer	B [mm]	B1 [mm]	C [mm]	D [mm]	H [mm]	F [mm]	S [mm]	Flange PN 16	Bolts Quan./Dim.	Weight [kg]
90.0	870757	870703	252.0	45.0	71.0	62.0	176.0	200	20	DN 80	8x, M16	8.9
90.0	870760	870706	252.0	45.0	71.0	62.0	178.0	220	20	DN 100	8x, M16	9.1
110.0	870763	870709	287.0	52.5	87.5	76.0	136.0	200	20	DN 80	8x, M16	9.5
110.0	870766	870712	287.0	52.5	87.5	76.0	188.0	220	20	DN 100	8x, M16	9.7

SDR 17

OD [mm]	Article DIN ⁴	Article multilayer	B [mm]	B1 [mm]	C [mm]	D [mm]	H [mm]	F [mm]	S [mm]	Flange PN 10	Bolts Quan./Dim.	Weight [kg]
90.0	870758	870704	252.0	45.0	77.0	66.8	176.0	200	20	DN 80	8x, M16	9.0
90.0	870761	870707	252.0	45.0	77.0	66.8	178.0	220	20	DN 100	8x, M16	9.2
110.0	870764	870710	287.0	52.5	94.5	82.3	136.0	200	20	DN 80	8x, M16	9.6
110.0	870767	870713	287.0	52.5	94.5	82.3	188.0	220	20	DN 100	8x, M16	9.8
125.0	870769	870715	287.0	52.5	108.0	95.0	136.0	200	20	DN 80	8x, M16	12.0
125.0	870772	870718	325.0	52.5	108.0	95.0	157.0	220	20	DN 100	8x, M16	12.2
160.0	870775	870721	287.0	52.5	138.5	124.5	161.0	200	20	DN 80	8x, M16	16.2
160.0	870778	870724	325.0	52.5	138.5	124.5	169.0	220	20	DN 100	8x, M16	16.9
160.0	870781	870727	363.0	52.5	138.5	124.5	229.0	285	22	DN 150	8x, M20	20.4
180.0	870784	870730	325.0	52.5	156.0	139.0	174.0	200	20	DN 80	8x, M16	19.6
180.0	870787	870733	325.0	52.5	156.0	139.0	182.0	220	20	DN 100	8x, M16	20.0
180.0	870790	870736	401.0	52.5	156.0	139.0	198.0	285	22	DN 150	8x, M20	23.4

Remarks:

- Flange according to DIN 2633 / EN 1092-1
- Test pressure at 20°C = 1.5 x PN
- Higher pressure ratings and additional dimensions are available on request
- For protecting pipes, please specify inside and outside diameters
- Pipe diameter range and tolerances ⇒ page 36
- Listed weight corresponds to the total product weight (liner insert and shells)
- Flange bolt set is not supplied

⁴ DIN ⇒ pipe dimensions according to EN 12201-2

⁷ for permanent temperatures above 20°C, please note the pressure specifications for PE pipes according to DIN 8074

Components	Materials
Shells	AISI 316 L or similar
Bolts	A4 - 80
Bars	AISI 316 L
Liner insert	Carbon steel, Rilsan coated (W270, NSF61, WRAS)
Medium	all qualities of water
Temperature	-5°C up to 40°C ⁷

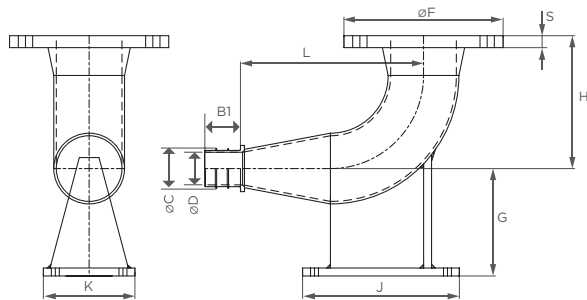

up to 110 mm: for PN 16 pipes ⁷
 from 125 mm: for PN 10 pipes ⁷

SDR 11

OD [mm]	Article		B1 [mm]	C [mm]	D [mm]	H [mm]	F [mm]	G [mm]	J [mm]	K [mm]	L [mm]	S [mm]	Flange PN 16	Bolts Quan./Dim.	Weight [kg]
	DIN ⁴	multilayer													
63.0	870850	870800	45.0	49.5	41.0	167.0	200	135.0	152.0	90	275.0	20	DN 80	8x, M16	9.4
90.0	870855	870805	45.0	71.0	62.0	167.0	200	135.0	152.0	115	235.0	20	DN 80	8x, M16	10.0
110.0	870860	870810	52.5	87.5	76.0	167.0	200	135.0	152.0	130	230.5	20	DN 80	8x, M16	10.7

SDR 17

OD [mm]	Article		B1 [mm]	C [mm]	D [mm]	H [mm]	F [mm]	G [mm]	J [mm]	K [mm]	L [mm]	S [mm]	Flange PN 10	Bolts Quan./Dim.	Weight [kg]
	DIN ⁴	multilayer													
90.0	870856	870806	45.0	77.0	66.8	167.0	200	135.0	152.0	115	190.0	20	DN 80	8x, M16	10.1
110.0	870861	870811	52.5	94.5	82.3	167.0	200	135.0	152.0	130	178.0	20	DN 80	8x, M16	10.8
125.0	870865	870815	52.5	108.0	95.0	167.0	200	135.0	152.0	150	242.5	20	DN 80	8x, M16	11.1
160.0	870870	870820	52.5	138.5	124.5	167.0	200	135.0	152.0	180	309.5	20	DN 80	8x, M16	16.2
180.0	870875	870825	52.5	156.0	139.0	167.0	200	135.0	152.0	200	346.5	20	DN 80	8x, M16	19.2

Remarks:

- Flange according to DIN 2633 / EN 1092-1
- Test pressure at 20°C = 1.5 x PN
- Higher pressure ratings and additional dimensions are available on request
- For protecting pipes, please specify inside and outside diameters
- Pipe diameter range and tolerances ⇒ page 36
- Listed weight corresponds to the total product weight (liner insert and shells)
- Flange bolt set is not supplied

⁴ DIN ⇒ pipe dimensions according to EN 12201-2

⁷ for permanent temperatures above 20°C, please note the pressure specifications for PE pipes according to DIN 8074

Components	Materials
Shells	AISI 316 L or similar
Bolts	A4 - 80
Bars	AISI 316 L
Liner insert	Carbon steel, Rilsan coated (W270, NSF61, WRAS)
Medium	all qualities of water
Temperature	-5°C up to 40°C ⁷

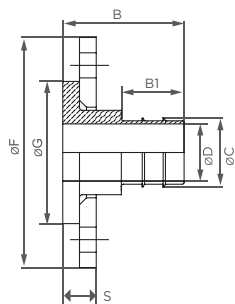

up to 110 mm: for PN 16 pipes ⁷
 from 125 mm: for PN 16 and PN 10 pipes ⁷
 > 180 mm: for PN 10 pipes ⁷

SDR 11

OD [mm]	Article DIN ⁴	Article multilayer	B [mm]	B1 [mm]	C [mm]	D [mm]	F [mm]	G ⁷ [mm]	S [mm]	Flange PN 16	Bolts Quan./Dim.	Weight [kg]
63.0	870936	870900	83.0	45.0	49.5	41.0	165	107.0	28	DN 50	4x, M16	2.4
63.0	870939	870903	85.0	45.0	49.5	41.0	202	142.0	30	DN 80	8x, M16	4.1
75.0	870942	870904 ³	85.0	45.0	59.5	50.5	187	127.0	28	DN 65	4x, M16	3.4
90.0	870945	870906	85.0	45.0	71.0	62.0	202	142.0	30	DN 80	8x, M16	3.8
110.0	870948	870909	92.5	52.5	87.5	76.0	220	162.0	30	DN 100	8x, M16	4.0
125.0	870963	870910	92.5	52.5	99.5	86.5	220	162.0	30	DN 100	8x, M16	4.6
140.0	870966	870911 ³	92.5	52.5	111.5	97.5	250	192.0	34	DN 125	8x, M16	6.6
160.0	870969	870914	104.5	52.5	127.5	113.5	286	218.0	36	DN 150	8x, M20	11.1
180.0	870972	870917	104.5	52.5	143.5	126.5	286	218.0	36	DN 150	8x, M20	10.2

SDR 17

OD [mm]	Article DIN ⁴	Article multilayer	B [mm]	B1 [mm]	C [mm]	D [mm]	F [mm]	G ⁷ [mm]	S [mm]	Flange PN 10	Bolts Quan./Dim.	Weight [kg]
90.0	870946	970907	85.0	45.0	77.0	66.8	200	138.0	30	DN 80	8x, M16	3.9
110.0	870949	870908	92.5	52.5	94.5	82.3	218	158.0	30	DN 100	8x, M16	5.0
125.0	870951	870912	92.5	52.5	108.0	95.0	220	162.0	30	DN 100	8x, M16	4.2
140.0	870954	870913 ³	92.5	52.5	121.0	107.0	250	192.0	34	DN 125	8x, M16	6.1
160.0	870957	870915	104.5	52.5	138.5	124.5	286	218.0	36	DN 150	8x, M20	10.2
180.0	870960	870918	104.5	52.5	156.0	139.0	286	218.0	36	DN 150	8x, M20	9.0
200.0	870975	870920 ³	127.0	52.5	173.5	154.5	340	273.0	39	DN 200	8x, M20	19.2
225.0	870922	870922	127.0	52.5	195.0	173.0	340	273.0	39	DN 200	8x, M20	17.7
250.0	870924	870924	133.0	52.5	217.0	193.0	409	328.0	45	DN 250	12x, M20	31.7
280.0	870926	870926	133.0	52.5	243.0	217.0	409	328.0	45	DN 250	12x, M20	27.0
315.0	870928	870928	150.0	62.5	273.0	243.0	463	378.0	52	DN 300	12x, M20	40.7
355.0	870930	870930	158.0	62.5	308.0	274.0	515	438.0	60	DN 350	16x, M20	54.5

Remarks:

- Flange according to DIN 2633 / EN 1092-1, hole pattern according to DIN EN 1092-1
- Test pressure at 20°C = 1.5 x PN
- Higher pressure ratings and additional dimensions are available on request
- For protecting pipes, please specify inside and outside diameters
- Pipe diameter range and tolerances ⇒ page 36
- Listed weight corresponds to the total product weight (liner insert and shells)
- Flange bolt set is not supplied

³ not available from our stock

⁴ DIN ⇒ pipe dimensions according to EN 12201-2

⁷ for permanent temperatures above 20°C, please note the pressure specifications for PE pipes according to DIN 8074

THE REPAIR CONCEPT

(Repair-Coupler)

Damaged PE pipes can easily be repaired with the STRAUB-PLAST-PRO repair-coupler. Repairs up to a length of 100 mm are possible.

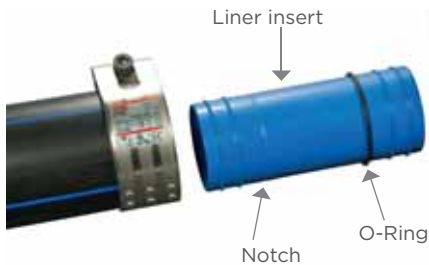

Expose 100 mm of pipe. Slightly bend the pipe ends sideward and insert the repair coupler to the O-Ring into one of the two pipe ends. Align the shells to the pipe ends.

The O-Ring prevents the repair coupler from completely sliding into the pipe.

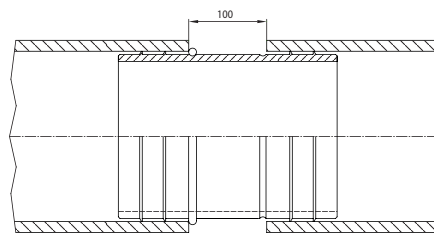

The pipe ends may be centred to each other again and the repair couplers aligned using the notches on the inner coupler. The clamps are to be tightened according to the torque indicated on the label.



Due to the variety of possible applications, STRAUB-PLAST-PRO is the genuine alternative to welding of PE pipes.

EXAMPLE STRAUB-PLAST-PRO R

(Reducer)

1



Slide the Shells over both pipes.

2



Push the reducer into the first tube until it stops.

3



Push the tubes together as far as they will go.

4



Align the shells to the pipe ends.

5



Tighten the locking bolts alternately with a torque wrench to the final torque rate indicated on the label of the shell. Repeat alternately the tightening sequence until a quarter turn (90°) or less is needed to reach the required torque.

- Complete kit
- Quickly and easily installed
- Installation without the need of external power supply
- May be installed in adverse weather conditions
- For pipe connections in contaminated soils
- Highly resistant against corrosion
- No pipe end preparation is required
- No dead end
- Stronger than a PE 100 pipe



THE FASTEST



TURN ON THE PIPE



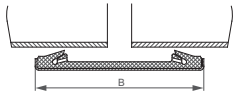
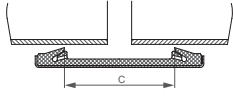
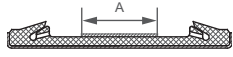
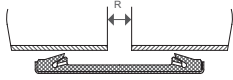
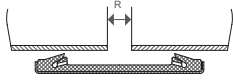

NON-AXIAL
RESTRAINT FLEXIBLE
PIPE COUPLINGS

SPECIFICATION

		STRAUB-FLEX / STRAUB-OPEN-FLEX				
		1	2	3	3.5	4
		[mm]	[mm]	[mm]	[mm]	[mm]
B Width of casing		75 - 107	138 - 148	210 - 218	310 - 311	443 - 444
C Distance between sealing lips		35 - 62	91	127	227	350
A Width of strip insert		29 - 52	70	100	200	300
R_{max} Pipe gap <i>without</i> strip insert		5	10	15	20	20
R_{max} Pipe gap <i>with</i> strip insert		15 - 35	35	60	120	200
Δ L Max. axial movement		5	10	15	15	20

THE AXIAL FLEXIBILITY SERIES

STRAUB-FLEX

All pipe materials can be reliably connected with STRAUB-FLEX couplings.

STRAUB-FLEX pipe couplings enable pipe connections for practically all conceivable pipe diameters, for the same or different types of pipe materials, various media and temperatures as well as for a wide range of the operating pressure values.

pipes must be secured axially using appropriate measures on-site such as tie rods, fixed and sliding points, concrete abutments etc.

The sealing sleeve separates the coupling casing from the pipe surface so that sound, vibrations and oscillations are optimally damped.

As STRAUB-FLEX pipe couplings cannot axially absorb any forces, the



- Outside diameter: 48.3 up to 4064.0 mm
- Temperature: -20°C up to +180°C (STRAUB-FLEX 3.5 + 4 up to +100°C)
- Sealing sleeve: EPDM, NBR, FPM/FKM



Components / Materials	W1	W2	W4	W5
Casing		AISI 316 L or similar		AISI 316 L or similar
Bolts		AISI 4135		A4 - 80
Bars		AISI 12L14, galvanised		AISI 316 L or similar
Strip insert (option)		AISI 316 L or similar / PVDF		AISI 316 L or similar / PVDF
Sealing sleeve EPDM	Temp.: -20°C up to +100°C Medium: all qualities of water, waste water, air, solids and chemical products			
Sealing sleeve NBR	Temp.: -20°C up to +80°C Medium: water, gas, oil, fuel and other hydrocarbons			
Sealing sleeve FPM/FKM¹²	Temp.: -20°C up to +180°C Medium: ozone, oxygen, acids, gas, oil and fuel (only with strip insert)			

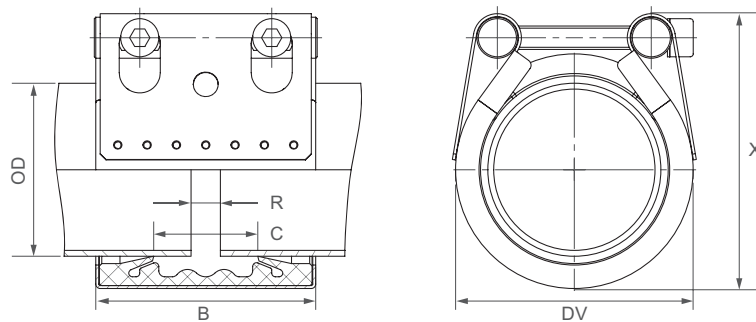

OD [mm]	Clamping range [mm]	PN [bar]	PN [bar]	B [mm]	C [mm]	DV [mm]	X [mm]	R without strip insert [mm]	R with strip insert [mm]	Torque rate [Nm]
48.3 ¹⁰	47.0 - 50.0	25	16	75	35	70	83	5	5 - 15	7.5
54.0 ¹⁰	52.5 - 55.5	25	16	75	35	76	88	5	5 - 15	7.5
57.0 ¹⁰	55.5 - 58.5	25	16	75	35	79	94	5	5 - 15	7.5
60.3	59.0 - 63.0	25	16	75	35	82	95	5	5 - 15	7.5
70.0	69.5 - 71.0	25	16	94	51	95	112	5	5 - 25	7.5
73.0	71.5 - 75.0	25	16	94	51	95	112	5	5 - 25	7.5
76.1	74.5 - 77.5	25	16	94	51	98	119	5	5 - 25	7.5
80.0	79.5 - 81.5	25	16	94	51	106	127	5	5 - 25	7.5
84.0	82.5 - 85.5	25	16	94	51	106	127	5	5 - 25	7.5
88.9	87.5 - 90.5	25	16	94	51	111	132	5	5 - 25	7.5
100.6	99.0 - 102.5	25	16	94	51	123	145	5	5 - 25	7.5
101.6	100.0 - 103.5	25	16	94	51	124	145	5	5 - 25	7.5
104.0	102.5 - 105.5	20	16	94	51	126	146	5	5 - 25	7.5
104.8	103.0 - 106.5	20	16	94	51	127	146	5	5 - 25	7.5
108.0	106.5 - 110.0	20	16	94	51	130	151	5	5 - 25	7.5
114.3	112.5 - 116.0	20	16	94	51	136	160	5	5 - 25	7.5
127.0	125.0 - 129.0	20	16	107	62	149	168	5	5 - 35	10
129.0	127.0 - 131.0	20	16	107	62	151	170	5	5 - 35	10
130.2	128.5 - 132.0	20	16	107	62	152	170	5	5 - 35	10
133.0	131.0 - 135.0	16	16	107	62	155	174	5	5 - 35	10
139.7	138.0 - 141.5	16	16	107	62	162	180	5	5 - 35	10
141.3	139.5 - 143.0	16	16	107	62	163	182	5	5 - 35	10
154.0	152.0 - 156.0	16	16	107	62	176	198	5	5 - 35	10
159.0	157.0 - 161.0	16	16	107	62	181	203	5	5 - 35	10
168.3	166.0 - 170.5	16	16	107	62	190	212	5	5 - 35	10

Remarks:

- Follow fitting instructions
- PN () = working pressure considering the application loads
Test pressure = PN () x 1.5 (for example industry, water supply etc.)
Burst pressure = approx. PN () x 2
- PN () = nominal pressure, includes four times safety factor (e.g. shipbuilding)
- Strip inserts are optional accessories (see page 87)
- Additional sealing sleeves, pressure and temperature ranges on request

¹⁰ FPM/FKM only available as STRAUB-OPEN-FLEX

Components / Materials	W1	W2	W4	W5
Casing	S355MC, hot-dip galvanised	AISI 316 L or similar		AISI 316 L or similar
Bolts	AISI 4135	AISI 4135		A4 - 80
Bars	AISI 12L14, galvanised	AISI 12L14, galvanised		AISI 316 L or similar
Strip insert (option)	AISI 316 L or similar / HDPE	AISI 316 L or similar / HDPE		AISI 316 L or similar / HDPE
Sealing sleeve EPDM	Temp.: -20°C up to +100°C Medium: all qualities of water, waste water, air, solids and chemical products			
Sealing sleeve NBR	Temp.: -20°C up to +80°C Medium: water, gas, oil, fuel and other hydrocarbons			
Sealing sleeve FPM/FKM	Temp.: -20°C up to +180°C Medium: ozone, oxygen, acids, gas, oil and fuel (only with strip insert)			

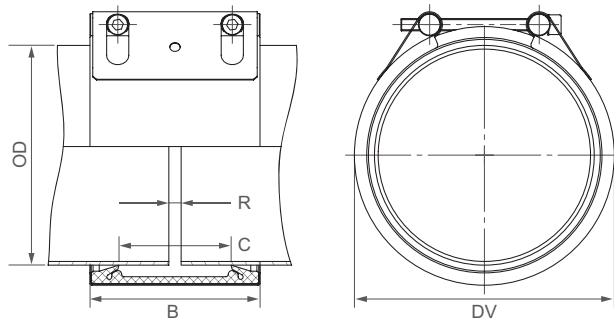

B ⇨ 138 up to 148 mm
 DV ⇨ OD + 27 mm
 C ⇨ 91 mm
 R with strip insert ⇨ 35 mm
 R without strip insert ⇨ 10 mm

	W2 or W5
	W1, W2 or W5
	W1 or W5
	only in W1 available

OD [mm]	Clamping range [mm]	PN					PN [bar]
		2.5	6	10	16	20	
172.0	170 - 174						
180.0	178 - 182						
200.0	198 - 202						
219.1	217 - 222						
250.0	248 - 253						
267.0	264 - 270						
273.0	270 - 276						
304.0	301 - 307						
323.9	321 - 327						
355.6	353 - 358						
406.4	404 - 409						
457.2	454 - 460						
508.0	505 - 511						
558.8	556 - 562						
609.6	606 - 613						
711.2	708 - 715						
762.0	758 - 766						
812.8	809 - 817						
914.4	910 - 918						
1016.0	1012 - 1020						
1117.6	1114 - 1122						
1219.2	1215 - 1224						
1320.8	1316 - 1325						
1422.4	1418 - 1427						
1524.0	1519 - 1529						
1600.0	1595 - 1605						
1625.6	1621 - 1631						
1727.2	1722 - 1732						
1828.8	1824 - 1834						
1930.4	1925 - 1935						
2032.0	2027 - 2037						

CONTINUOUSLY VARIABLE INTERMEDIATE SIZES FROM 172.0 TO 2032.0 mm ARE AVAILABLE

Remarks:

- Follow fitting instructions
- PN () = working pressure considering the application loads
 Test pressure = PN () x 1.5 (for example industry, water supply etc.)
 Burst pressure = approx. PN () x 2
 PN () = nominal pressure, includes four times safety factor (e.g. shipbuilding)
- Strip inserts are optional accessories (see page 87)
- Additional sealing sleeves, pressure and temperature ranges on request

⇨ Bigger diameters are available as STRAUB-OPEN-FLEX, see page 60 to 65

Components / Materials	W1	W2	W4	W5
Casing	S355MC, hot-dip galvanised	AISI 316 L or similar		AISI 316 L or similar
Bolts	AISI 4135	AISI 4135		A4 - 80
Bars	AISI 12L14, galvanised	AISI 12L14, galvanised		AISI 316 L or similar
Strip insert (option)	AISI 316 L or similar / HDPE	AISI 316 L or similar / HDPE		AISI 316 L or similar / HDPE
Sealing sleeve EPDM	Temp.: -20°C up to +100°C Medium: all qualities of water, waste water, air, solids and chemical products			
Sealing sleeve NBR	Temp.: -20°C up to +80°C Medium: water, gas, oil, fuel and other hydrocarbons			
Sealing sleeve FPM/FKM (on request)	Temp.: -20°C up to +180°C Medium: ozone, oxygen, acids, gas, oil and fuel (only with strip insert)			

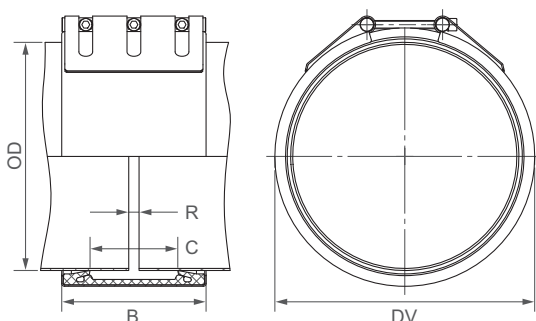

B ⇨ 210 up to 218 mm
 DV ⇨ OD + 38 mm
 C ⇨ 127 mm
 R with strip insert ⇨ 60 mm
 R without strip insert ⇨ 15 mm

	W2 or W5
	W1, W2 or W5
	W1 or W5
	only in W1 available



OD [mm]	Clamping range [mm]	PN					
		2.5	6	10	16	20	25
219.1	216 - 222						
250.0	247 - 253						
267.0	264 - 270						
273.0	270 - 276						
304.0	301 - 307						
323.9	321 - 327						
355.6	352 - 358						
406.4	403 - 409						
457.2	454 - 460						
508.0	504 - 512						
558.8	555 - 562						
609.6	606 - 613						
711.2	707 - 715						
762.0	758 - 766						
812.8	809 - 817						
914.4	910 - 918						
1016.0	1012 - 1020						
1117.6	1113 - 1122						
1219.2	1215 - 1224						
1320.8	1316 - 1325						
1422.4	1418 - 1427						
1524.0	1519 - 1529						
1600.0	1595 - 1605						
1625.6	1621 - 1631						
1727.2	1722 - 1732						
1828.8	1824 - 1834						
1930.4	1925 - 1935						
2032.0	2027 - 2037						

CONTINUOUSLY VARIABLE INTERMEDIATE SIZES FROM 219.1 TO 2032.0 mm ARE AVAILABLE

Remarks:

- Follow fitting instructions
- PN = working pressure considering the application loads
 Test pressure = PN x 1.5 (for example industry, water supply etc.)
 Burst pressure = approx. PN x 2
- Strip inserts are optional accessories (see page 87)
- Additional sealing sleeves, pressure and temperature ranges on request

⇨ Bigger diameters are available as STRAUB-OPEN-FLEX, see page 60 to 65

Components / Materials	W1	W2	W4	W5
Casing	S355MC, hot-dip galvanised			S32101 (LDX)
Bolts	AISI 4135			A4 - 80
Bars	AISI 12L14, galvanised			AISI 316 L or similar
Strip insert	AISI 316 L or similar / HDPE			AISI 316 L or similar / HDPE
Sealing sleeve EPDM	Temp.: -20°C up to +100°C Medium: all qualities of water, waste water, air, solids and chemical products			
Sealing sleeve NBR	Temp.: -20°C up to +80°C Medium: water, gas, oil, fuel and other hydrocarbons			

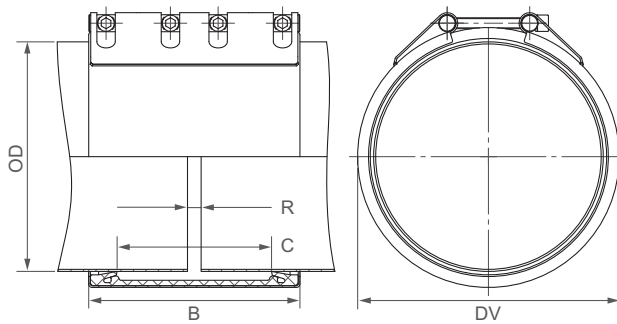

B ⇒ 310 up to 311 mm
 DV ⇒ OD + 38 mm
 C ⇒ 227 mm
 R with strip insert ⇒ 120 mm
 R without strip insert ⇒ 20 mm

	W1 or W5
	only in W5 available



OD [mm]	Clamping range [mm]	PN					
		2.5	6	10	16	20	25
323.9	320 - 327						
355.6	352 - 370						
406.4	402 - 410						
457.2	453 - 461						
508.0	504 - 512						
558.8	555 - 563						
609.6	605 - 614						
655.0	651 - 659						
711.2	707 - 715						
762.0	758 - 766						
812.8	809 - 817						
914.4	910 - 918						
1016.0	1011 - 1021						
1117.6	1112 - 1123						
1219.2	1214 - 1224						

CONTINUOUSLY VARIABLE INTERMEDIATE SIZES FROM 323.9 TO 1219.2 mm ARE AVAILABLE

Remarks:

- Follow fitting instructions
- PN = working pressure considering the application loads
 Test pressure = PN x 1.5 (for example industry, water supply etc.)
 Burst pressure = approx. PN x 2
- Strip inserts included
- Additional sealing sleeves, pressure and temperature ranges on request

⇒ Bigger diameters are available as STRAUB-OPEN-FLEX, see page 60 to 65

Components / Materials	W1	W2	W4	W5
Casing	S355MC, hot-dip galvanised			S32101 (LDX)
Bolts	AISI 4135			A4 - 80
Bars	AISI 12L14, galvanised			AISI 316 L or similar
Strip insert	AISI 301 / HDPE			AISI 316 L or similar / HDPE
Sealing sleeve EPDM	Temp.: -20°C up to +100°C Medium: all qualities of water, waste water, air, solids and chemical products			
Sealing sleeve NBR	Temp.: -20°C up to +80°C Medium: water, gas, oil, fuel and other hydrocarbons			

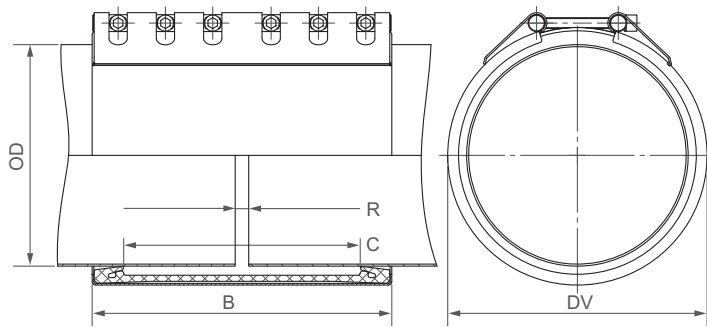

B ⇨ 443 up to 444 mm
 DV ⇨ OD + 48 mm
 C ⇨ 350 mm
 R with strip insert ⇨ 200 mm
 R without strip insert ⇨ 20 mm

	W1 or W5
	only in W5 available



OD [mm]	Clamping range [mm]	PN					
		2.5	6	10	16	20	25
323.9	320 - 327						
355.6	352 - 359						
406.4	403 - 409						
457.2	454 - 460						
508.0	505 - 512						
558.8	555 - 562						
609.6	606 - 613						
655.0	652 - 658						
711.2	707 - 715						
762.0	758 - 766						
812.8	809 - 817						

CONTINUOUSLY VARIABLE INTERMEDIATE SIZES FROM 323.9 TO 812.8 mm ARE AVAILABLE

Remarks:

- Follow fitting instructions
- PN = working pressure considering the application loads
 Test pressure = PN x 1.5 (for example industry, water supply etc.)
 Burst pressure = approx. PN x 2
- Strip inserts included
- Additional sealing sleeves, pressure and temperature ranges on request

⇨ Bigger diameters are available as STRAUB-OPEN-FLEX, see page 60 to 65

FLEXIBLE AND VERSATILE **STRAUB-OPEN-FLEX**



With joint, slotted casing, 2-part or 3-part, STRAUB-OPEN-FLEX can be mounted easily and quickly on existing pipes.

STRAUB-OPEN-FLEX pipe couplings have the same characteristics as STRAUB-FLEX couplings, but expand their possible uses.

The casings of the STRAUB-OPEN-FLEX product series can be hinged or available as 2-part or 3-part version. As a result, STRAUB-OPEN-FLEX couplings can be used for connecting pipes or repairs without removal of existing pipes.



-
- Outside diameter: 48.3 up to 4064.0 mm
 - Temperature: -20°C up to +180°C (OPEN-FLEX 3.5 + 4 up to +100°C)
 - Sealing sleeve: EPDM, NBR, FPM/FKM
-



Components / Materials	W1	W2	W4	W5
Casing		AISI 316 L or similar		AISI 316 L or similar
Bolts		AISI 4135		A4 - 80
Bars		AISI 12L14, galvanised		AISI 316 L
Strip insert (option)		AISI 316 L or similar / VDF		AISI 316 L or similar / PVDF
Sealing sleeve EPDM	Temp.: -20°C up to +100°C Medium: all qualities of water, waste water, air, solids and chemical products			
Sealing sleeve NBR	Temp.: -20°C up to +80°C Medium: water, gas, oil, fuel and other hydrocarbons			
Sealing sleeve FPM/FKM	Temp.: -20°C up to +180°C Medium: ozone, oxygen, acids, gas, oil and fuel (only with strip insert)			

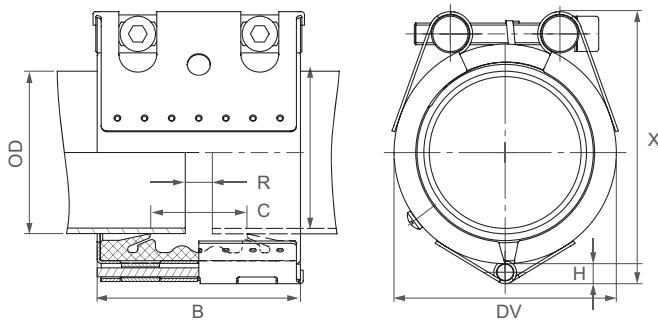

OD [mm]	High H [mm]
48.3 - 60.3	7.0
73.0 - 114.3	9.0
127.0 - 168.3	9.5



OD [mm]	Clamping range [mm]	PN [bar]	PN [bar]	B [mm]	C [mm]	DV [mm]	X [mm]	R without strip insert [mm]	R with strip insert [mm]	Torque rate [Nm]
48.3	47.0 - 50.0	25	16	75	35	70	89	5	15	7.5
54.0	52.5 - 55.5	25	16	75	35	76	94	5	15	7.5
57.0	55.5 - 58.5	25	16	75	35	79	97	5	15	7.5
60.3	59.0 - 63.0	25	16	75	35	82	101	5	15	7.5
73.0	71.5 - 75.0	25	16	94	51	95	119	5	25	10
76.1	74.5 - 77.5	25	16	94	51	98	123	5	25	10
84.0	82.5 - 85.5	25	16	94	51	106	131	5	25	10
88.9	87.5 - 90.5	25	16	94	51	111	136	5	25	10
100.6	99.0 - 102.5	25	16	94	51	123	148	5	25	10
101.6	100.0 - 103.5	25	16	94	51	124	148	5	25	10
104.0	102.5 - 105.5	20	16	94	51	126	152	5	25	10
104.8	103.0 - 106.5	20	16	94	51	127	152	5	25	10
108.0	106.5 - 110.0	20	16	94	51	130	156	5	25	10
114.3	112.5 - 116.0	20	16	94	51	136	162	5	25	10
118.0	116.0 - 120.0	20	16	94	51	140	166	5	25	10
127.0	125.0 - 129.0	20	16	107	62	149	179	5	35	12
129.0	127.0 - 131.0	20	16	107	62	151	181	5	35	12
130.2	128.5 - 132.0	20	16	107	62	152	181	5	35	12
133.0	131.0 - 135.0	16	16	107	62	155	189	5	35	12
139.7	138.0 - 141.5	16	16	107	62	162	192	5	35	12
141.3	139.5 - 143.0	16	16	107	62	163	192	5	35	12
154.0	152.0 - 156.0	16	16	107	62	176	207	5	35	12
159.0	157.0 - 161.0	16	16	107	62	181	212	5	35	12
168.3	166.0 - 170.5	16	16	107	62	190	225	5	35	12

Remarks:

- Follow fitting instructions
- PN () = working pressure considering the application loads
Test pressure = PN () x 1.5 (for example industry, water supply etc.)
PN () = nominal pressure, includes four times safety factor (e.g. shipbuilding)
- Strip inserts are optional accessories (see page 87)
- Additional sealing sleeves, pressure and temperature ranges on request

STRAUB-OPEN-FLEX 1 GT

(with side outlet)

ø 73.0 - 168.3 mm

Components / Materials	W1	W2	W4	W5
Casing		AISI 316 L or similar		AISI 316 L or similar
Bolts		AISI 4135		A4 - 80
Bars		AISI 12L14, galvanised		AISI 316 L
Sealing sleeve EPDM	Temp.: -20°C up to +70°C Medium: all qualities of water, waste water, air, solids and chemical products			
Sealing sleeve NBR	Temp.: -20°C up to +70°C Medium: water, gas, oil, fuel and other hydrocarbons			

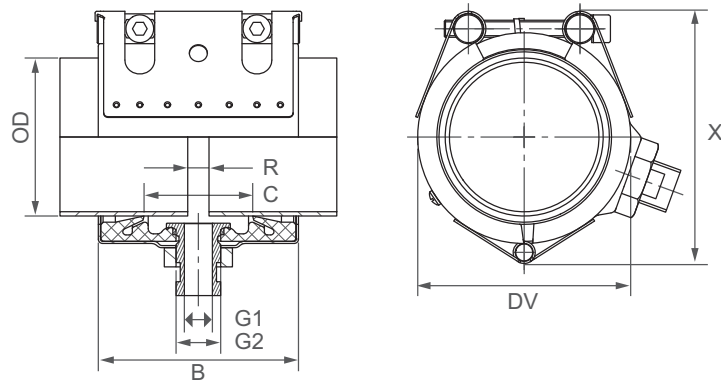

OD [mm]	Clamping range [mm]	PN [bar]	B [mm]	C [mm]	DV [mm]	X [mm]	G1 [Inch]	G2 [Inch]	Torque rate [Nm]
73.0	71.5 - 74.5	16	94	51	95	119	1/4	1/2	10
76.1	74.5 - 77.5	16	94	51	98	123	1/4	1/2	10
84.0	82.5 - 85.5	16	94	51	106	131	1/4	1/2	10
88.9	87.5 - 90.5	16	94	51	111	136	1/4	1/2	10
100.6	99.0 - 102.5	16	94	51	123	148	1/4	1/2	10
101.6	100.0 - 103.5	16	94	51	124	148	1/4	1/2	10
104.0	102.5 - 105.5	16	94	51	126	152	1/4	1/2	10
104.8	103.0 - 106.5	16	94	51	127	152	1/4	1/2	10
108.0	106.5 - 109.5	16	94	51	130	156	1/4	1/2	10
114.3	112.5 - 116.0	16	94	51	136	162	1/4	1/2	10
118.0	116.0 - 120.0	16	94	51	140	166	1/4	1/2	10
127.0	125.0 - 129.0	16	107	62	149	179	3/4	1	12
129.0	127.0 - 131.0	16	107	62	151	181	3/4	1	12
130.2	128.5 - 132.0	16	107	62	152	181	3/4	1	12
133.0	131.0 - 135.0	16	107	62	155	189	3/4	1	12
139.7	138.0 - 141.5	16	107	62	162	192	3/4	1	12
141.3	139.5 - 143.0	16	107	62	163	192	3/4	1	12
154.0	152.0 - 156.0	16	107	62	176	207	3/4	1	12
159.0	157.0 - 161.0	16	107	62	181	212	3/4	1	12
168.3	166.0 - 170.5	16	107	62	190	225	3/4	1	12

Remarks:

- Follow fitting instructions
- PN = working pressure considering the application loads
Test pressure = PN x 1.5 (for example industry, water supply etc.)
- Strip inserts not to be applied
- Not suitable for vacuum applications
- Additional sealing sleeves, pressure and temperature ranges on request

Components / Materials	W1	W2	W4	W5
Casing	S355MC, hot-dip galvanised	AISI 316 L or similar		AISI 316 L or similar
Bolts	AISI 4135	AISI 4135		A4 - 80
Bars	AISI 12L14, galvanised	AISI 12L14, galvanised		AISI 316 L or similar
Strip insert (option)	AISI 316 L or similar / HDPE	AISI 316 L or similar / HDPE		AISI 316 L or similar / HDPE

Sealing sleeve EPDM	Temp.: -20°C up to +100°C	Medium: all qualities of water, waste water, air, solids and chemical products
Sealing sleeve NBR	Temp.: -20°C up to +80°C	Medium: water, gas, oil, fuel and other hydrocarbons
Sealing sleeve FPM/FKM	Temp.: -20°C up to +180°C	Medium: ozone, oxygen, acids, gas, oil and fuel (only with strip insert)

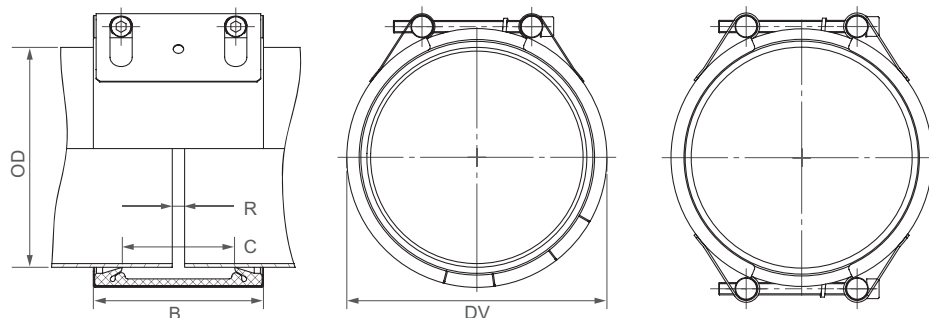

B ⇨ 138 up to 148 mm
 DV ⇨ OD + 27 mm
 C ⇨ 91 mm
 R with strip insert ⇨ 35 mm
 R without strip insert ⇨ 10 mm

	W2 or W5
	W1, W2 or W5
	W1 or W5
	only in W1 available

OD [mm]	Clamping range [mm]	PN					PN [bar]
		2.5	6	10	16	20	
172.0	170 - 174						
180.0	178 - 182						
200.0	198 - 202						
219.1	217 - 222						
250.0	248 - 253						
267.0	264 - 270						
273.0	270 - 276						
304.0	301 - 307						
323.9	321 - 327						
355.6	353 - 358						
406.4	404 - 409						
457.2	454 - 460						
508.0	505 - 511						
558.8	556 - 562						
609.6	606 - 613						
711.2	708 - 715						
762.0	758 - 766						
812.8	809 - 817						
914.4	910 - 918						
1016.0	1012 - 1020						
1117.6	1114 - 1122						
1219.2	1215 - 1224						
1320.8	1316 - 1325						
1422.4	1418 - 1427						
1524.0	1519 - 1529						
1600.0	1595 - 1605						
1625.6	1621 - 1631						
1727.2	1722 - 1732						
1828.8	1824 - 1834						
1930.4	1925 - 1935						
2032.0	2027 - 2037						

Pressure rates according to type approval

CONTINUOUSLY VARIABLE INTERMEDIATE SIZES FROM 172.0 TO 2032.0 mm ARE AVAILABLE

Remarks:

- Follow fitting instructions
- PN () = working pressure considering the application loads
 Test pressure = PN () x 1.5 (for example industry, water supply etc.)
 PN () = nominal pressure, includes four times safety factor (e.g. shipbuilding)
- Strip inserts are optional accessories (see page 87)
- Additional sealing sleeves, pressure and temperature ranges on request

Versions:

2.5	6	PN				1 piece (slotted) [mm]	2 piece casing [mm]
		10	16	20	25		
x	x					≤1219.1	on order
x	x					172.0-355.6	on order
		x				457.2-711.2	on order
		x				>711.2	on order
			x			≤219.1	on order
			x			219.1-1524.0	on order
				x		172.0-1016.0	on order
					x	180.0-762.0	on order

STRAUB-OPEN-FLEX 2 GT

(with side outlet)

ø 172.0 - 2032.0 mm

Components / Materials	W1	W2	W4	W5
Casing	S355MC, hot-dip galvanised	AISI 316 L or similar		AISI 316 L or similar
Bolts	AISI 4135	AISI 4135		A4 - 80
Bars	AISI 12L 14, galvanised	AISI 12L 14, galvanised		AISI 316 L or similar
Strip insert (on request)	AISI 316 L / HDPE	AISI 316 L / HDPE		AISI 316 L / HDPE
GT side outlet	AISI 316 L	AISI 316 L		AISI 316 L

Sealing sleeve EPDM	Temp.: -20°C up to +70°C			
	Medium: all qualities of water, waste water, air, solids and chemical products			
Sealing sleeve NBR	Temp.: -20°C up to +70°C			
	Medium: water, gas, oil, fuel and other hydrocarbons			

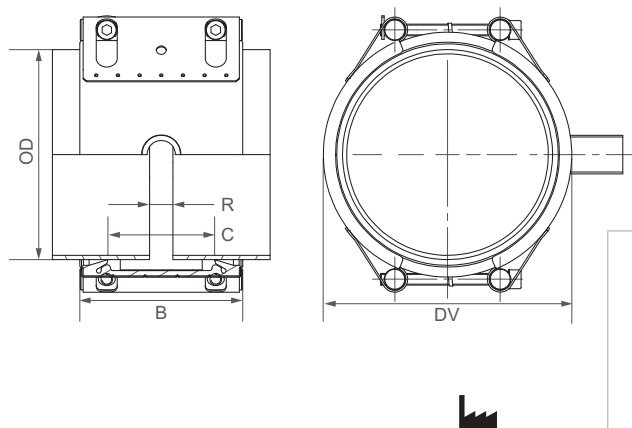

DV ⇨ OD + 27 mm
 C ⇨ 91 mm
 R with strip insert ⇨ 35 mm
 R without strip insert ⇨ 10 mm

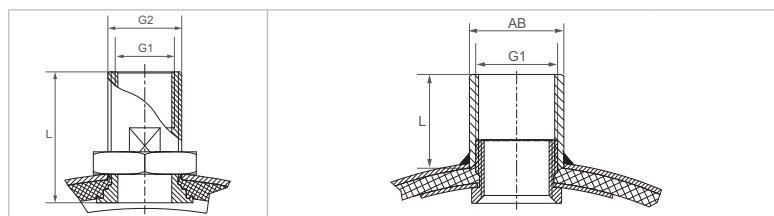

		PN					version 1	version 2	version 3	version 4	version 5	version 6
		2.5	6	10	16	20	screwed	screwed	welded	welded	welded	welded
G1							G 1/4"	G 3/4"	G 1"	G 1 1/4"	G 1 1/2"	G 2"
G2 / AB							G 1/2"	G 1"	39.5 mm	48.3 mm	54.5 mm	66.3 mm
L									43.0 mm	48.0 mm	48.0 mm	56.0 mm
OD [mm]	Clamping range [mm]											
172.0	170 - 174						X	X				
180.0	178 - 182						X	X	X			
200.0	198 - 202						X	X	X			
219.1	217 - 222						X	X	X			
250.0	248 - 253						X	X	X			
267.0	264 - 270						X	X	X			
273.0	270 - 276						X	X	X	X		
304.0	301 - 307						X	X	X	X		
323.9	321 - 327						X	X	X	X		
355.6	353 - 358						X	X	X	X		
406.4	404 - 409						X	X	X	X	X	
457.2	454 - 460						X	X	X	X	X	
508.0	505 - 511						X	X	X	X	X	
558.8	556 - 562						X	X	X	X	X	X
609.6	606 - 613						X	X	X	X	X	X
711.2	708 - 715						X	X	X	X	X	X
762.0	758 - 766						X	X	X	X	X	X
812.8	809 - 817						X	X	X	X	X	X
914.4	910 - 918						X	X	X	X	X	X
1016.0	1012 - 1020						X	X	X	X	X	X
1117.6	1114 - 1122						X	X	X	X	X	X
1219.2	1215 - 1224						X	X	X	X	X	X
1320.8	1316 - 1325						X	X	X	X	X	X
1422.4	1418 - 1427						X	X	X	X	X	X
1524.0	1519 - 1529						X	X	X	X	X	X
1600.0	1595 - 1605						X	X	X	X	X	X
1625.6	1621 - 1631						X	X	X	X	X	X
1727.2	1722 - 1732						X	X	X	X	X	X
1828.8	1824 - 1834						X	X	X	X	X	X
1930.4	1925 - 1935						X	X	X	X	X	X
2032.0	2027 - 2037						X	X	X	X	X	X

CONTINUOUSLY VARIABLE INTERMEDIATE SIZES FROM 172.0 TO 2032.0 mm ARE AVAILABLE
 STRAUB-OPEN-FLEX 3 GT, 3.5 GT AND 4 GT WITH OUTLET G3/4"1" AVAILABLE AS WELL

Remarks:

- Follow fitting instructions
- PN = working pressure considering the application loads
 Test pressure = PN x 1.5 (for example industry, water supply etc.)
- Version 1 + 2 with outside- and inside thread
- Version 3 - 6 with inside thread and outside blank (AB)
- Only in two-piece version available

Typing errors may occur. Technical details are subject to change.

Components / Materials	W1	W2	W4	W5
Casing	S355MC, hot-dip galvanised	AISI 316 L or similar		AISI 316 L or similar
Bolts	AISI 4135	AISI 4135		A4 - 80
Bars	AISI 12L14, galvanised	AISI 12L14, galvanised		AISI 316 L or similar
Strip insert (option)	AISI 316 L or similar / HDPE	AISI 316 L or similar / HDPE		AISI 316 L or similar / HDPE
Sealing sleeve EPDM	Temp.: -20°C up to +100°C Medium: all qualities of water, waste water, air, solids and chemical products			
Sealing sleeve NBR	Temp.: -20°C up to +80°C Medium: water, gas, oil, fuel and other hydrocarbons			
Sealing sleeve FPM/FKM (on request)	Temp.: -20°C up to +180°C Medium: ozone, oxygen, acids, gas, oil and fuel (only with strip insert)			

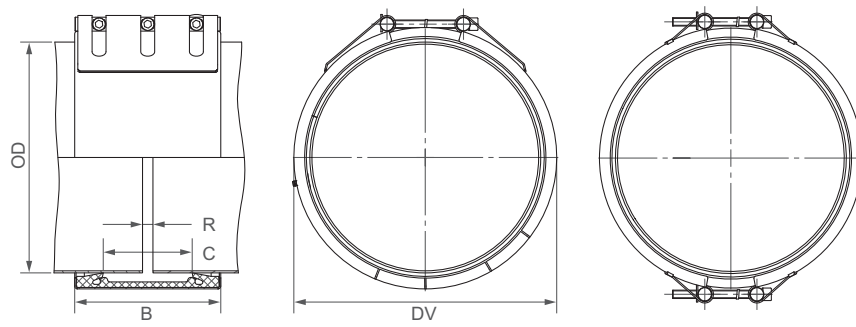

B ⇨ 210 up to 218 mm
 DV ⇨ OD + 38 mm
 C ⇨ 127 mm
 R with strip insert ⇨ 60 mm
 R without strip insert ⇨ 15 mm

	W2 or W5
	W1, W2 or W5
	W1 or W5
	only in W1 available

OD [mm]	Clamping range [mm]	PN					
		2.5	6	10	16	20	25
219.1	216 - 222						
250.0	247 - 253						
267.0	264 - 270						
273.0	270 - 276						
304.0	301 - 307						
323.9	321 - 327						
355.6	352 - 358						
406.4	403 - 409						
457.2	454 - 460						
508.0	504 - 512						
558.8	555 - 562						
609.6	606 - 613						
711.2	707 - 715						
762.0	758 - 766						
812.8	809 - 817						
914.4	910 - 918						
1016.0	1012 - 1020						
1117.6	1113 - 1122						
1219.2	1215 - 1224						
1320.8	1316 - 1325						
1422.4	1418 - 1427						
1524.0	1519 - 1529						
1600.0	1595 - 1605						
1625.6	1621 - 1631						
1727.2	1722 - 1732						
1828.8	1824 - 1834						
1930.4	1925 - 1935						
2032.0	2027 - 2037						
2268.0	2263 - 2273						
2540.0	2535 - 2545						
2794.0	2789 - 2799						
3048.0	3043 - 3053						
3302.0	3296 - 3308						
3556.0	3548 - 3562						
3810.0	3804 - 3816						
4064.0	4058 - 4070						

CONTINUOUSLY VARIABLE INTERMEDIATE SIZES FROM 219.1 TO 4064.0 mm ARE AVAILABLE

Remarks:

- Follow fitting instructions
- PN = working pressure considering the application loads
Test pressure = PN x 1.5 (for example industry, water supply etc.)
- Strip inserts are optional accessories (see page 87)
- Additional sealing sleeves, pressure and temperature ranges on request

Versions:

PN						1 piece (slotted) [mm]	2 piece casing [mm]	3 piece casing [mm]
2.5	6	10	16	20	25			
x						219.1 - 1219.2 (2 pc. casing on order)	1219.2 - 3048.0	>3048.0
	x					508.0 - 914.4 (2 pc. casing on order)	219.1 - 508.0	>3048.0
		x				508.0 (2 pc. casing on order)	914.4 - 3048.0	>3048.0
			x	x	x		219.1 - 2540.0	

⇨ pressure rating definition, see above



Components / Materials	W1	W2	W4	W5
Casing	S355MC, hot-dip galvanised			S32101 (LDX)
Bolts	AISI 4135			A4 - 80
Bars	AISI 12L14, galvanised			AISI 316 L or similar
Strip insert	AISI 316 L or similar / HDPE			AISI 316 L or similar / HDPE
Sealing sleeve EPDM	Temp.: -20°C up to +100°C Medium: all qualities of water, waste water, air, solids and chemical products			
Sealing sleeve NBR	Temp.: -20°C up to +80°C Medium: water, gas, oil, fuel and other hydrocarbons			

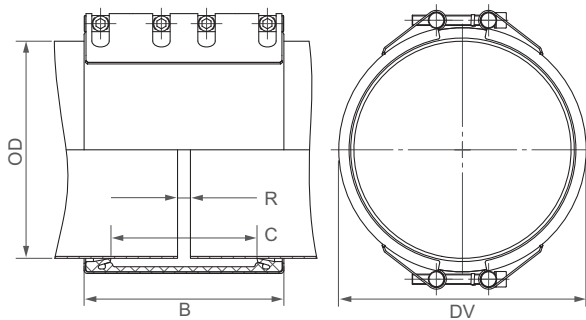

B ⇒ 310 up to 311 mm
 DV ⇒ OD + 38 mm
 C ⇒ 227 mm
 R with strip insert ⇒ 120 mm
 R without strip insert ⇒ 20 mm

	W1 or W5
	only in W5 available

OD [mm]	Clamping range [mm]	PN					
		2.5	6	10	16	20	25
323.9	320 - 327						
355.6	352 - 370						
406.4	402 - 410						
457.2	453 - 461						
508.0	504 - 512						
558.8	555 - 563						
609.6	605 - 614						
655.0	651 - 659						
711.2	707 - 715						
762.0	758 - 766						
812.8	809 - 817						
914.4	910 - 918						
1016.0	1011 - 1021						
1117.6	1112 - 1123						
1219.2	1214 - 1224						
1320.8	1316 - 1325						
1422.4	1417 - 1427						
1524.0	1519 - 1529						
1600.0	1595 - 1605						
1625.0	1620 - 1630						
1727.2	1722 - 1732						
1828.8	1824 - 1834						
1930.4	1925 - 1935						
2032.0	2026 - 2038						
2268.0	2262 - 2274						
2540.0	2534 - 2546						
2794.0	2788 - 2800						
3048.0	3042 - 3054						
3302.0	3296 - 3308						
3556.0	3550 - 3562						
3810.0	3804 - 3816						
4064.0	4058 - 4070						

CONTINUOUSLY VARIABLE INTERMEDIATE SIZES FROM 323.9 TO 4064.0 mm ARE AVAILABLE

Remarks:

- Follow fitting instructions
- PN = working pressure considering the application loads
Test pressure = PN x 1.5 (for example industry, water supply etc.)
- Strip inserts included
- Additional sealing sleeves, pressure and temperature ranges on request

Versions:

PN						2 piece casing	3 piece casing
2.5	6	10	16	20	25	[mm]	[mm]
x	x	x	x	x	x	≤3048.0	>3048.0

⇒ pressure rating definition, see above

Components / Materials	W1	W2	W4	W5
Casing	S355MC, hot-dip galvanised			S32101 (LDX)
Bolts	AISI 4135			A4 - 80
Bars	AISI 12L14, galvanised			AISI 316 L or similar
Strip insert	AISI 301 / HDPE			AISI 316 L or similar / HDPE
Sealing sleeve EPDM	Temp.: -20°C up to +100°C Medium: all qualities of water, waste water, air, solids and chemical products			
Sealing sleeve NBR	Temp.: -20°C up to +80°C Medium: water, gas, oil, fuel and other hydrocarbons			

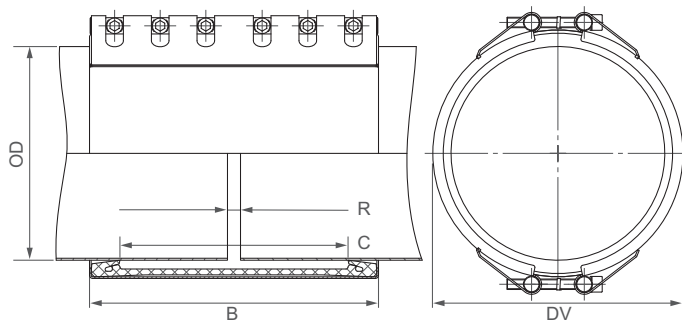

B ⇨ 443 up to 444 mm
 DV ⇨ OD + 48 mm
 C ⇨ 350 mm
 R with strip insert ⇨ 200 mm
 R without strip insert ⇨ 20 mm

W1 or W5
only in W5 available



OD [mm]	Clamping range [mm]	PN					
		2.5	6	10	16	20	25
323.9	320 - 327						
355.6	352 - 359						
406.4	403 - 409						
457.2	454 - 460						
508.0	505 - 512						
558.8	555 - 562						
609.6	606 - 613						
655.0	652 - 658						
711.2	707 - 715						
762.0	758 - 766						
812.8	809 - 817						
914.4	910 - 918						
1016.0	1012 - 1020						
1117.6	1113 - 1122						
1219.2	1215 - 1224						
1320.8	1316 - 1325						
1422.4	1418 - 1427						
1524.0	1519 - 1529						
1600.0	1595 - 1605						
1625.0	1621 - 1631						
1727.2	1722 - 1732						
1828.8	1824 - 1834						
1930.4	1925 - 1935						
2032.0	2027 - 2037						
2268.0	2263 - 2273						
2540.0	2535 - 2545						
2794.0	2798 - 2799						
3048.0	3043 - 3053						
3302.0	3296 - 3308						
3556.0	3548 - 3562						
3810.0	3804 - 3816						
4064.0	4058 - 4070						

CONTINUOUSLY VARIABLE INTERMEDIATE SIZES FROM 323.9 TO 4064.0 mm ARE AVAILABLE

Remarks:

- Follow fitting instructions
- PN = working pressure considering the application loads
Test pressure = PN x 1.5 (for example industry, water supply etc.)
- Strip inserts included
- Additional sealing sleeves, pressure and temperature ranges on request

Versions:

PN						2 piece casing [mm]	3 piece casing [mm]
2.5	6	10	16	20	25	≤3048.0	>3048.0
x	x	x	x	x	x		

⇨ pressure rating definition, see above

DNV GL
FIRE PROVED
STRAUB COUPLING

STRAUB-OPEN-FLEX FIRE-FENCE

Fire-endurance test in accordance with ISO 19921 and 19922



Components / Materials	W1	W2	W4	W5
Casing				S32101
Bolts				AISI 316 L
Bars				AISI 316 L or similar
Strip insert (option)				HDPE
Sealing sleeve EPDM	Temp.: -20°C up to +100°C	Medium: all qualities of water, waste water, air, solids and chemical products		
Sealing sleeve NBR	Temp.: -20°C up to +80°C	Medium: water, gas, oil, fuel and other hydrocarbons		

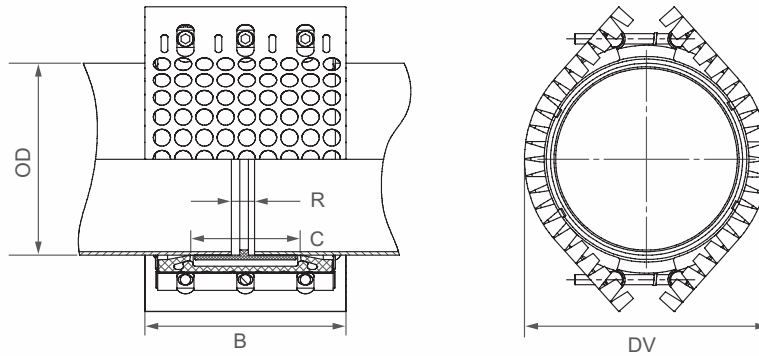

OD [mm]	Clamping range [mm]	PN [bar]	B [mm]	C [mm]	DV [mm]	R without strip insert [mm]	R with strip insert [mm]	Torque rate [Nm]
219.1	216 - 222	5 ¹¹	235	127	285	40	15	60
250.0	247 - 253	5 ¹¹	235	127	316	40	15	60
267.0	264 - 270	5 ¹¹	235	127	333	40	15	60
273.0	270 - 276	6	235	127	339	40	15	60
304.0	301 - 307	5	235	127	370	40	15	60
323.9	321 - 327	5	235	127	393	40	15	60
406.4	403 - 409	5	235	127	475	40	15	60

Remarks:

- Follow fitting instructions
- Strip inserts included
- Approved according to ISO 19921-1 and ISO 19922-2 / DIN 86228-1 and DIN86228-2
- Approved according to IACS URP2

¹¹ for service other than flammable fluids ⇒ PN 6 bar



Components / Materials	W1	W2	W4	W5
Casing				S32101
Bolts				AISI 316 L
Bars				AISI 316 L or similar
Strip insert (option)				HDPE
Sealing sleeve EPDM	Temp.: -20°C up to +100°C	Medium: all qualities of water, waste water, air, solids and chemical products		
Sealing sleeve NBR	Temp.: -20°C up to +80°C	Medium: water, gas, oil, fuel and other hydrocarbons		

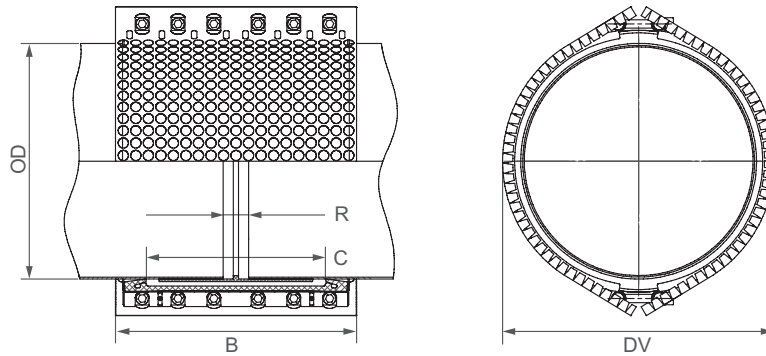

OD [mm]	Clamping range [mm]	PN [bar]	B [mm]	C [mm]	DV [mm]	R without strip insert [mm]	R with strip insert [mm]	Torque rate [Nm]
323.9	320 - 327	6	472	350	399	20	200	40
355.6	352 - 359	6	472	350	431	20	200	40
406.4	403 - 409	6	472	350	481	20	200	40
457.2	454 - 460	6	472	350	532	20	200	40
508.0	505 - 512	6	472	350	583	20	200	40
558.8	555 - 562	6 ¹²	472	350	634	20	200	40
609.6	606 - 613	6 ¹²	472	350	685	20	200	40
655.0	652 - 658	6 ¹²	472	350	730	20	200	40
711.2	707 - 715	6 ¹²	472	350	786	20	200	40
762.0	758 - 766	6 ¹²	472	350	837	20	200	40
812.8	809 - 817	6 ¹²	472	350	888	20	200	50

Remarks:

- Follow fitting instructions
- Strip inserts included
- Approved according to ISO 19921-1 and ISO 19922-2 / DIN 86228-1 and DIN86228-2
- Approved according to IACS URP2

¹² not approved

CONNECTS ALL PIPE MATERIALS AND DIFFERENT PIPE DIAMETERS

STRAUB-STEP-FLEX

STRAUB-STEP-FLEX is used if the pipes have different external diameters.

The possible diameter differences of the pipes to be connected can be 10 mm up to max. 30 mm. Larger diameter differences can be achieved using the integration of a reduction fitting piece with two couplings. Smaller diameter differences (5 - 9 mm) can be bridged on request using our STRAUB-FLEX 2 / 3.

Under pressure, STRAUB-STEP-FLEX pipe couplings, due to the diameter differences, are always pushed by internal forces in the direction of the smaller pipe diameter and must therefore be secured against slipping using appropriate measures.

Thrust rings are available on request; retainers are not necessary for non-pressurised applications.



- Outside diameter: 219.1 up to 2032.0 mm
- Temperature: -20°C up to +100°C
- Sealing sleeve: EPDM
- diameter difference up to 30 mm

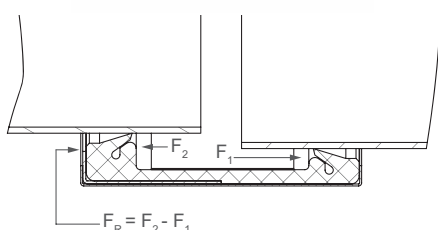

	OD 1 [mm]	OD 2 [mm]	min [bar]	Coupling retainer F_R at PN min [N]	max [bar]	Coupling retainer F_R at PN max [N]
STRAUB-STEP-FLEX 2	250.0	280.0	12.0	14980	24.0	29960
	323.9	353.0	9.5	14690	25.0	38860
	406.4	436.0	7.5	14680	25.0	48940
	609.6	639.0	5.0	14410	25.0	72040
	812.8	842.0	3.5	13195	22.0	82938
STRAUB-STEP-FLEX 3	1219.2	1249.0	3.5	20210	17.0	98160
	1600.0	1630.0	2.5	19020	13.5	102690
	2032.0	2062.0	2.0	19280	10.0	96410
	3048.0	3078.0	3.0	43280	6.5	93770
	4064.0	4094.0	1.0	19210	5.0	96060

Components / Materials	W1	W2	W4	W5
Casing	S355MC, hot-dip galvanised	AISI 316 L or similar		AISI 316 L or similar
Bolts	AISI 4135	AISI 4135		A4 - 80
Bars	AISI 12L14, galvanised	AISI 12L14, galvanised		AISI 316 L or similar
Strip insert	AISI 316 L or similar	AISI 316 L or similar		AISI 316 L or similar

Sealing sleeve Temp.: -20°C up to +100°C
EPDM Medium: all qualities of water, waste water, air, solids and chemical products

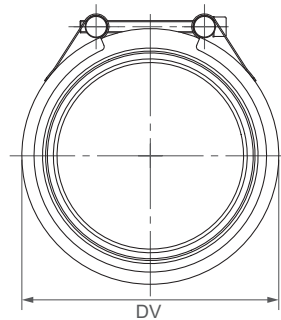
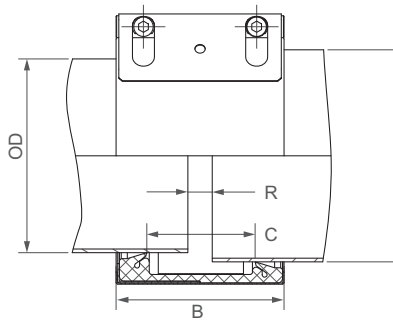

DV ⇨ OD + 27 mm
 C ⇨ 91 mm
 R with strip insert ⇨ 35 mm
 R without strip insert ⇨ 10 mm

	W2 or W5
	W1, W2 or W5
	W1 or W5
	only in W1 available

OD 1 [mm]	OD 2 min (OD 1 + 10 mm) [mm]	OD 2 max (OD 1 + 30 mm) [mm]	PN					
			2.5	6	10	16	20	25
219.1	230	250						
250.0	260	280						
267.0	277	297						
273.0	283	303						
304.0	314	334						
323.9	334	354						
355.6	366	386						
406.4	416	436						
457.2	467	487						
508.0	518	538						
558.8	569	589						
609.6	620	640						
711.2	721	741						
762.0	772	792						
812.8	823	843						

CONTINUOUSLY VARIABLE INTERMEDIATE SIZES FROM 219.1 TO 812.8 mm ARE AVAILABLE

Remarks:

- Follow fitting instructions
- PN = working pressure considering the application loads
 Test pressure = PN x 1.5 (for example industry, water supply etc.)
- Stainless steel strip insert included
- Additional sealing sleeves, pressure and temperature ranges on request

Components / Materials	W1	W2	W4	W5
Casing	S355MC, hot-dip galvanised	AISI 316 L or similar		AISI 316 L or similar
Bolts	AISI 4135	AISI 4135		A4 - 80
Bars	AISI 12L14, galvanised	AISI 12L14, galvanised		AISI 316 L or similar
Strip insert	AISI 316 L or similar	AISI 316 L or similar		AISI 316 L or similar

Sealing sleeve Temp.: -20°C up to +100°C
EPDM Medium: all qualities of water, waste water, air, solids and chemical products

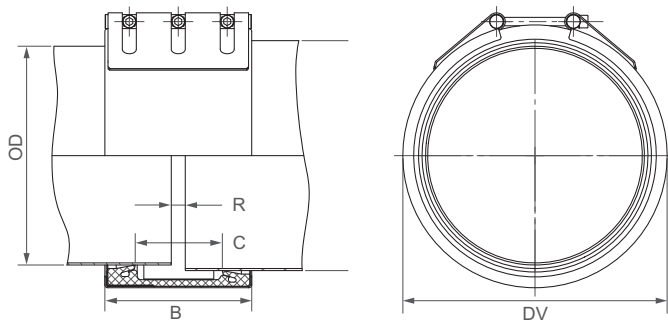

DV ⇨ OD + 38 mm
 C ⇨ 127 mm
 R with strip insert ⇨ 60 mm
 R without strip insert ⇨ 15 mm

	W2 or W5
	W1, W2 or W5
	W1 or W5
	only in W1 available

OD 1 [mm]	OD 2 min (OD 1 + 10 mm) [mm]	OD 2 max (OD 1 + 30 mm) [mm]	PN					
			2.5	6	10	16	20	25
914.4	924	934						
1016.0	1026	1046						
1117.6	1127	1147						
1219.2	1229	1249						
1320.8	1331	1351						
1422.4	1432	1452						
1524.0	1534	1554						
1600.0	1610	1630						
1625.4	1635	1655						
1727.2	1737	1757						
1828.8	1839	1859						
1930.4	1940	1960						
2032.0	2042	2062						

CONTINUOUSLY VARIABLE INTERMEDIATE SIZES FROM 914.4 TO 2032.0 mm ARE AVAILABLE

Remarks:

- Follow fitting instructions
- PN = working pressure considering the application loads
 Test pressure = PN x 1.5 (for example industry, water supply etc.)
- Stainless steel strip insert included
- Additional sealing sleeves, pressure and temperature ranges on request

FOR SQUARE PIPES

STRAUB-SQUARE-FLEX

STRAUB connects square pipes, easily, quickly and reliably with STRAUB-SQUARE-FLEX

The main application area of STRAUB-SQUARE-FLEX is piping in water treatment plants for biological waste water purification. STRAUB-SQUARE-FLEX is used on square pipes in aeration basins.



-
- Dimension: 60 / 80 / 100 mm
 - Temperature: -20°C up to +100°C
 - Sealing sleeve: EPDM
-

Components / Materials	W1	W2	W4	W5
Casing				AISI 316 L
Bolts				A4 - 80
Bars				AISI 316 L

Sealing sleeve Temp.: -20°C up to +100°C
EPDM Medium: all qualities of water, waste water, air, solids and chemical products

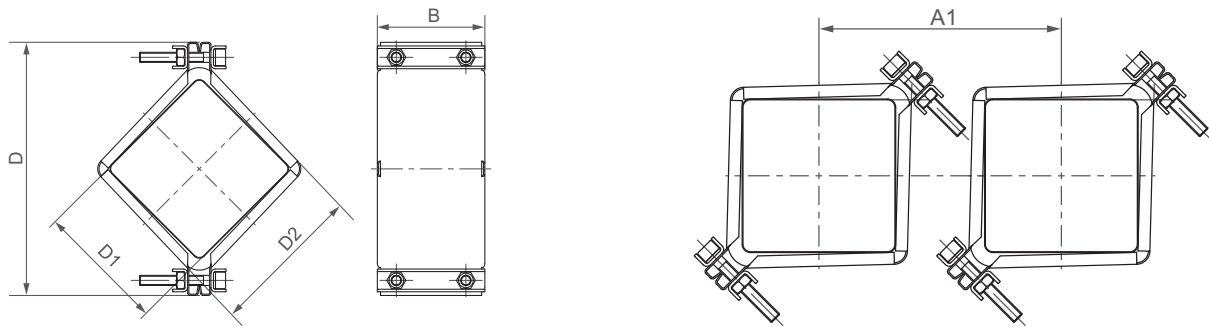

Dimension [mm]	PN [bar]	D [mm]	D1 [mm]	D2 [mm]	B [mm]	A1 [mm]	Torque rate [Nm]	Allen head [mm]	Thread M...
60.0	4	142	60	83	85	125	10	6	8
80.0	4	171	80	103	85	140	10	6	8
100.0	4	200	100	123	85	170	10	6	8

Remarks:

- Follow fitting instructions

A close-up photograph of a mechanical assembly, likely a power tool or engine component. The image shows a red handle on the right, a silver metal body, and a threaded metal part in the foreground. The background is dark and out of focus. The text "STRAUB REPAIR PRODUCTS" is overlaid on the right side of the image.

STRAUB
REPAIR PRODUCTS

THE ALL ROUND REPAIR *COUPLING*

STRAUB-REP-FLEX

The coupling for the reliably repairing of laterally broken pipes, cracks and the leakage of pipes caused by corrosion.

The STRAUB-REP-FLEX is intended to be used for the fast and reliably repairing of broken pipes and the leakage of water/drinking water pipes, as well as gas- and oilpipes caused by corrosion.

The proven STRAUB sealing lip system provides dependable and durable application on pipes of various materials such as steel, cast iron, ductile cast iron, fibre cement, PVC or PE.

In addition, two different materials of the same DN can be connected using STRAUB-REP-FLEX.

The EPDM sealing sleeve meets all requirements of SVGW, ÖVGW, WRC and NSF as well as DVGW W270 and KTW.



- Outside diameter: DN 40 up to DN 400
- Temperature: -20°C up to +100°C
- Sealing sleeve: EPDM, NBR



Damaged area on a pipe; quickly and reliably sealed with a STRAUB-REP-FLEX coupling.

Components	Materials
Jacket sheet	AISI 304
Bolts	AISI 304
Bars	AISI 304

Sealing sleeve EPDM	Temp.: -20°C up to +100°C
	Medium: all qualities of water, waste water, air, solids and chemical products
Sealing sleeve NBR	Temp.: -20°C up to +80°C
	Medium: water, gas, oil, fuel and other hydrocarbons

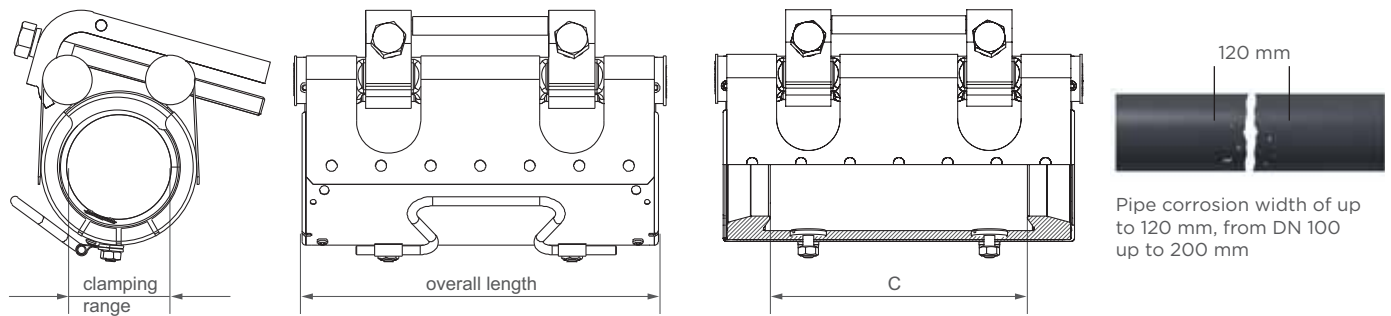

DN	Clamping range [mm]	Overall length [mm]	PN [bar]	C [mm]	Cast iron [mm]	Old cast iron [mm]	Steel [mm]	PE [mm]	Torque rate [Nm]	Allen head [mm]	Thread M...
40	46 - 53	200	16	142	-	51 - 53	46.0 - 49.0	50	10	17	10
40	53 - 60	200	16	142	56	-	-	-	10	17	10
50	56 - 64	200	16	142	-	62 - 64	56.0 - 61.0	63	10	17	10
50 / 60	63 - 71	200	16	142	66	-	70.0 - 71.0	-	10	17	10
60 / 65	72 - 80	200	16	142	77	72 - 74	72.0 - 76.1	75	10	17	10
65 / 70	76 - 83	200	16	142	82	-	77.0 - 79.0	-	10	17	10
70	82 - 89	200	16	142	87	83 - 85	-	-	10	17	10
80	88 - 98	200	16	142	98	94 - 96	88.0 - 89.0	90	10	17	10
90	97 - 108	200	16	142	108	104 - 108	97.0 - 102.0	-	10	17	10
100	108 - 118	200 / 300	16	142 / 245	118	114 - 116	107.0 - 114.3	110/125	10	17	10
100	120 - 130	200 / 300	16	142 / 245	-	123 - 125	-	-	10	17	10
100 / 125	128 - 138	200 / 300	16	142 / 245	-	134 - 137	132.0 - 134.0	-	10	17	10
125	139 - 149	200 / 300	16	142 / 245	144	140 - 143	139.7	140	10	17	10
135 / 150	150 - 160	200 / 300	16	142 / 245	-	150 - 153	157.0 - 160.0	160	10	17	10

CONTINUOUSLY VARIABLE INTERMEDIATE SIZES ON REQUEST

Remarks:

- Follow fitting instructions
- Test pressure = PN x 1.5
- Assembly on pipes can be of various materials

Components	Materials
Jacket sheet	AISI 304
Bolts	AISI 304
Bars	AISI 304

Sealing sleeve EPDM	Temp.: -20°C up to +100°C
	Medium: all qualities of water, waste water, air, solids and chemical products
Sealing sleeve NBR	Temp.: -20°C up to +80°C
	Medium: water, gas, oil, fuel and other hydrocarbons

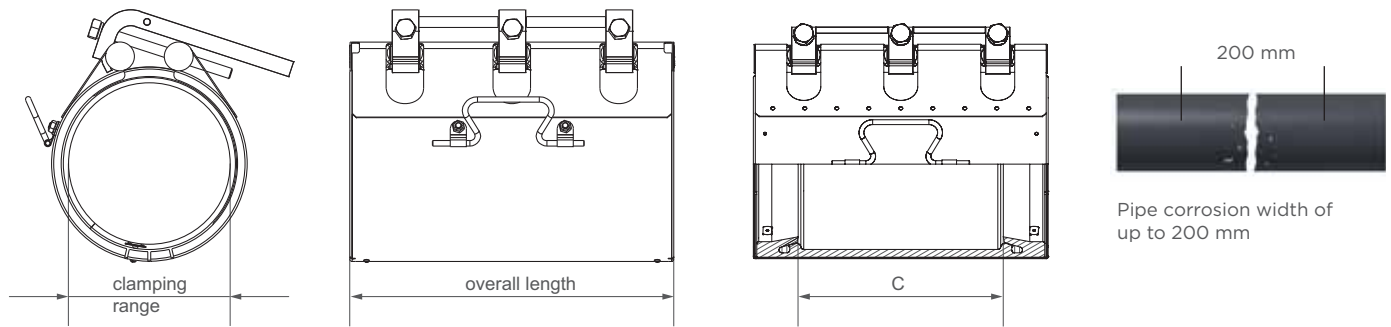

DN	Clamping range [mm]	Overall length [mm]	PN [bar]	C [mm]	Cast iron [mm]	Old cast iron [mm]	Steel [mm]	PE [mm]	Torque rate [Nm]	Allen head [mm]	Thread M...
150	159 - 170	300	16	212	170	166 - 169	168.3	160	20	19	12
165	175 - 185	300	16	212	-	180 - 184	-	-	20	19	12
175	186 - 196	300	16	212	196	191 - 194	183.0 - 191.0	-	20	19	12
175 / 180	196 - 206	300	16	212	-	198 - 200	-	200	20	19	12
190 / 200	206 - 216	300	16	212	-	208 - 211	211.0 - 216.0	-	20	19	12
200	216 - 226	300	16	212	222	218 - 222	219.1	225	20	19	12
225	241 - 251	300	16	212	248	244 - 247	241.0	250	20	19	12
250	264 - 274	300	16	212	274	268 - 273	264.0 - 273.0	-	20	19	12
250	274 - 284	300	16	212	-	-	-	280	20	19	12
300	315 - 325	300	10	212	324	322 - 325	316.0 - 323.9	315	20	19	12
350	355 - 365	300	10	212	-	-	355.6	355	20	19	12
350	368 - 379	300	10	212	378	376 - 379	368.0	-	20	19	12
400	398 - 408	300	10	212	-	-	406.4	400	20	19	12
400	419 - 429	300	10	212	429	426 - 430	419.0	-	20	19	12

CONTINUOUSLY VARIABLE INTERMEDIATE SIZES AND BIGGER DIAMETERS ON REQUEST

Remarks:

- Follow fitting instructions
- Test pressure = PN x 1.5
- Assembly on pipes can be of various materials

THE REPAIR *CLAMP*

STRAUB-CLAMP

In single-part and two-part design for reliable repair of gas, water and waste water pipes made of different materials.

Repair Clamps provide a safe and reliable sealing of damaged pipes made of a wide range of materials (steel, cast iron, ductile cast iron, fibre cement, PVC). Repairs on large damaged areas up to 250 mm are possible.

The repair clamp must be at least as long as the outside diameter of the pipe being repaired. Prepare the pipe surface according to the general installation requirements (please refer to the STRAUB-CLAMP fitting instructions).

The STRAUB-CLAMP repair clamp is manufactured with the standard seals out of EPDM resp., NBR and is available as a one or two-piece version.



- Outside diameter: 44.0 up to 420.0 mm
- Temperature: -5°C up to +40°C
- Sealing sleeve: EPDM, NBR

- Ideal for repairing large damaged areas
- Easy handling and fitting



Components	Materials
Casing	AISI 304
Bolts	A2 - 70
Bars	AISI 304

Sealing sleeve EPDM	Temp.: -5°C up to +40°C Medium: all qualities of water, waste water, air, solids and chemical products
Sealing sleeve NBR	Temp.: -5°C up to +40°C Medium: water, gas, oil, fuel and other hydrocarbons

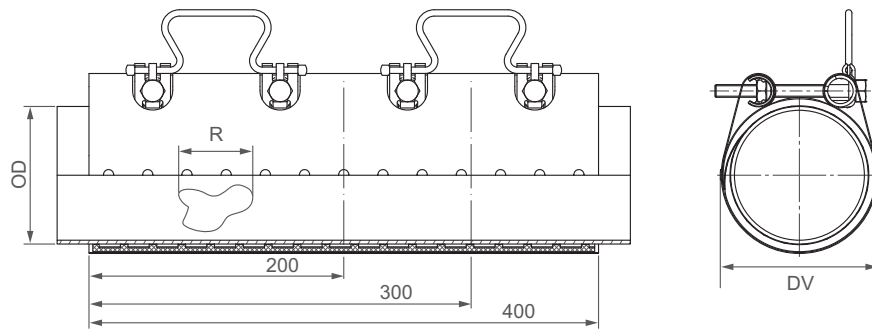

Clamp length [mm]	R _{max} [mm]
200	50
300	150
400	250



OD [mm]	Clamping range [mm]	PN ¹³ [bar]	2 locking bolts [mm]	3 locking bolts [mm]	4 locking bolts [mm]	DV [mm]	Torque rate [Nm]	Allen head [mm]	Thread M...
44.0	44 - 48	16	200	300	-	60	20	17	10
48.0	48 - 52	16	200	300	-	64	20	17	10
54.0	54 - 58	16	200	300	-	70	20	17	10
60.0	60 - 67	16	200	300	-	79	20	17	10
67.0	67 - 74	16	200	300	-	86	20	17	10
70.0	70 - 77	16	200	300	-	89	20	17	10
75.0	75 - 83	16	200	300	-	95	20	17	10
82.0	82 - 89	16	200	300	400	101	20	17	10
87.0	87 - 95	16	200	300	400	107	20	17	10
88.0	88 - 98	16	200	300	400	110	20	17	10
95.0	95 - 104	16	200	300	400	116	20	17	10
108.0	108 - 118	16	200	300	400	120	20	17	10
113.0	113 - 123	16	200	300	400	135	20	17	10
118.0	118 - 128	16	200	300	400	140	20	17	10
120.0	120 - 131	16	200	300	400	143	20	17	10
132.0	132 - 142	16	200	300	400	154	35	19	12
135.0	135 - 145	16	200	300	400	157	35	19	12
139.0	139 - 149	16	200	300	400	161	35	19	12
145.0	145 - 155	16	200	300	400	167	35	19	12
159.0	159 - 170	16	200	300	400	182	35	19	12
167.0	167 - 178	16	200	300	400	190	35	19	12
176.0	176 - 187	16	200	300	400	199	35	19	12
193.0	193 - 203	10	200	300	400	215	35	19	12
215.0	215 - 225	10	200	300	400	237	35	19	12
228.0	228 - 239	10	200	300	-	251	35	19	12
240.0	240 - 250	10	200	300	-	262	35	19	12
261.0	261 - 271	10	200	300	-	283	35	19	12
269.0	269 - 280	10	200	300	-	292	35	19	12
280.0	280 - 291	10	-	300	-	303	35	19	12
315.0	315 - 325	10	-	300	-	337	40	19	12
320.0	320 - 330	10	-	300	-	342	40	19	12

Remarks:

- Follow fitting instructions
- Test pressure = PN x 1.5
- Different pipe diameters (transition) are not possible
- Radial length of damaged area max. 20% of pipe outside diameters
- The repair clamp must be centred over the damaged area

¹³ working pressure for gas: max. 5 bar

Components	Materials
Casing	AISI 304
Bolts	A2 - 70
Bars	AISI 304

Sealing sleeve EPDM	Temp.: -5°C up to +40°C	Medium: all qualities of water, waste water, air, solids and chemical products
Sealing sleeve NBR	Temp.: -5°C up to +40°C	Medium: water, gas, oil, fuel and other hydrocarbons

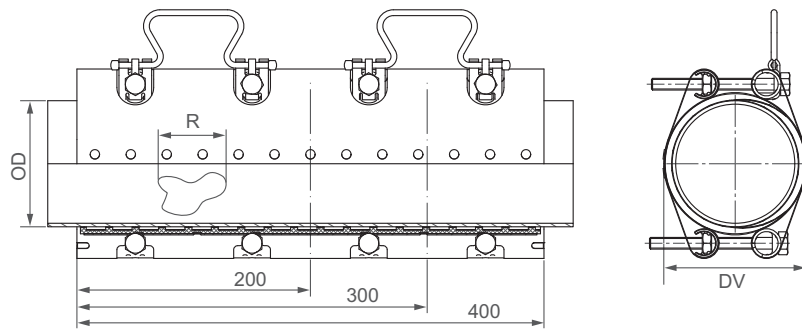

Clamp length [mm]	R _{max} [mm]
200	50
300	150
400	250



OD [mm]	Clamping range [mm]	PN ¹³ [bar]	2 locking bolts [mm]	3 locking bolts [mm]	4 locking bolts [mm]	DV [mm]	Torque rate [Nm]	Allen head [mm]	Thread M...
88.0	88 - 110	16	200	300	400	117	20	17	10
100.0	100 - 120	16	200	300	400	132	20	17	10
108.0	108 - 128	16	200	300	400	140	20	17	10
114.0	114 - 134	16	200	300	400	146	20	17	10
120.0	120 - 140	16	200	300	400	152	20	17	10
130.0	130 - 150	16	200	300	400	162	20	19	12
140.0	140 - 160	16	200	300	400	172	35	19	12
159.0	159 - 180	16	200	300	400	192	35	19	12
168.0	168 - 189	16	200	300	400	201	35	19	12
190.0	190 - 210	16	200	300	400	223	35	19	12
210.0	210 - 230	10	200	300	400	242	35	19	12
218.0	218 - 238	10	200	300	400	252	35	19	12
240.0	240 - 260	10	200	300	400	272	35	19	12
269.0	269 - 289	10	200	300	400	301	35	19	12
282.0	282 - 302	10	200	300	400	314	35	19	12
315.0	315 - 335	10	200	300	400	347	40	19	12
322.0	322 - 344	10	-	300	400	356	40	19	12
337.0	337 - 358	6	-	300	400	370	40	19	12
347.0	347 - 367	6	-	300	400	379	40	19	12
365.0	365 - 385	5	-	-	400	397	40	19	12
390.0	390 - 410	5	-	-	400	422	40	19	12
410.0	410 - 430	5	-	-	400	442	40	19	12
420.0	420 - 440	5	-	-	400	452	40	19	12

Remarks:

- Follow fitting instructions
- Test pressure = PN x 1.5
- Different pipe diameters (transition) are not possible
- Radial length of damaged area max. 20% of pipe outside diameters
- The repair clamp must be centred over the damaged area

¹³ working pressure for gas: max. 5 bar

SAFE, FAST, REUSABLE **STRAUB SHAPED PARTS** **WITH EXTENDED ENDS**

Innovative and economical piping constructions with the new STRAUB shaped parts program and the proven STRAUB couplings.



Compressed air system in V2A with STRAUB shaped parts and STRAUB couplings.

ELBOW 90° TYPE 3

welded DIN 2605 / EN 10253

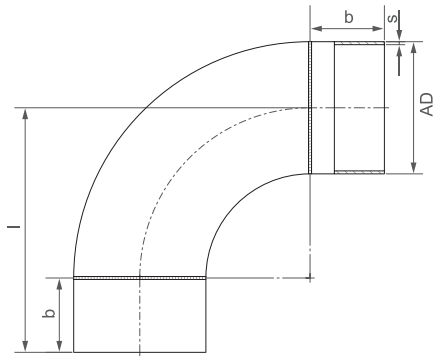

DN	PN [bar]	OD [mm]	b [mm]	s [mm]	l [mm]	Weight [kg/pce]	Material	
							V2A	V4A
32	16	42.4	40	2.0	85	0.31	AISI 304 L	AISI 316 TI
40	16	48.3	40	2.0	97	0.39	AISI 304 L	AISI 316 TI
50	16	60.3	40	2.0	116	0.58	AISI 304 L	AISI 316 TI
65	16	76.1	55	2.0	150	0.96	AISI 304 L	AISI 316 TI
80	16	88.9	55	2.0	169	1.26	AISI 304 L	AISI 316 TI
100	16	114.3	55	2.0	207	1.97	AISI 304 L	AISI 316 TI
125	16	139.7	120	2.6	310	4.59	AISI 304	AISI 316 TI
150	16	168.3	120	2.6	349	6.17	AISI 304	AISI 316 TI
200	16	219.1	155	3.0	460	12.48	AISI 304	AISI 316 TI

Remarks:

- additional versions and dimensions are available on request (e.g. AISI 304 / AISI 316 L)

ELBOW 45° TYPE 3

welded DIN 2605 / EN 10253

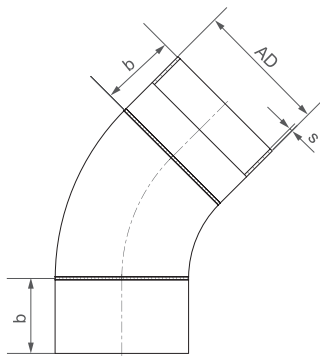

DN	PN [bar]	OD [mm]	b [mm]	s [mm]	Weight [kg/pce]	Material	
						V2A	V4A
32	16	42.4	40	2.0	0.24	AISI 304 L	AISI 316 TI
40	16	48.3	40	2.0	0.29	AISI 304 L	AISI 316 TI
50	16	60.3	40	2.0	0.41	AISI 304 L	AISI 316 TI
65	16	76.1	55	2.0	0.69	AISI 304 L	AISI 316 TI
80	16	88.9	55	2.0	0.87	AISI 304 L	AISI 316 TI
100	16	114.3	55	2.0	1.29	AISI 304 L	AISI 316 TI
125	16	139.7	120	2.6	3.37	AISI 304	AISI 316 TI
150	16	168.3	120	2.6	4.38	AISI 304	AISI 316 TI
200	16	219.1	155	3.0	8.76	AISI 304	AISI 316 TI

Remarks:

- additional versions and dimensions are available on request (e.g. AISI 304 / AISI 316 L)

EQUAL TEE

welded DIN 2615 / EN 10253-4

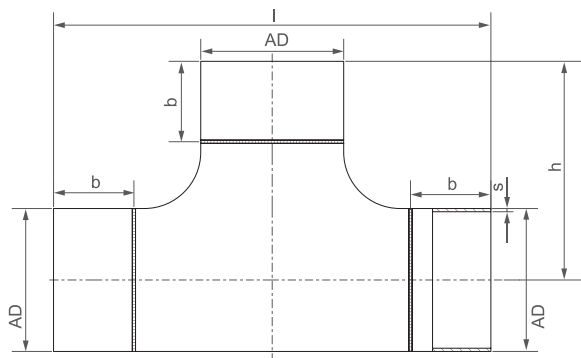

DN	PN [bar]	OD [mm]	h [mm]	s [mm]	l [mm]	Weight [kg/pce]	Material	
							V2A	V4A
32	16	42.4	100	2.0	200	0.84	AISI 304	AISI 316 TI
40	16	48.3	105	2.0	210	1.00	AISI 304	AISI 316 TI
50	16	60.3	115	2.0	230	1.35	AISI 304	AISI 316 TI
65	16	76.1	145	2.0	290	2.08	AISI 304	AISI 316 TI
80	16	88.9	150	2.0	300	2.57	AISI 304	AISI 316 TI
100	16	114.3	165	2.0	330	4.71	AISI 304	AISI 316 TI
125	16	139.7	190	2.6	380	6.56	AISI 304	AISI 316 TI
150	16	168.3	210	2.6	420	8.54	AISI 304	AISI 316 TI
200	16	219.1	275	3.0	550	16.28	AISI 304	AISI 316 TI

REDUCING TEE

welded DIN 2615 / EN 10253-4

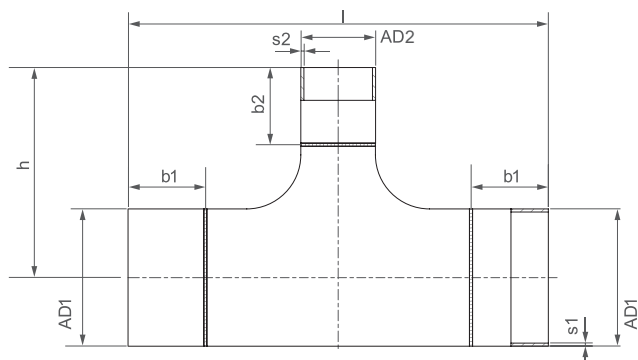

DN / DN	PN [bar]	OD 1 [mm]	OD 2 [mm]	h [mm]	s1 [mm]	s2 [mm]	l [mm]	Weight [kg/pce]	Material	
									V2A	V4A
40 / 32	16	48.3	42.4	105	2.0	2.0	210	1.00	AISI 304	AISI 316 TI
50 / 40	16	60.3	48.3	115	2.0	2.0	230	1.35	AISI 304	AISI 316 TI
65 / 50	16	76.1	60.3	145	2.0	2.0	290	2.08	AISI 304	AISI 316 TI
80 / 65	16	88.9	76.1	150	2.0	2.0	300	2.57	AISI 304	AISI 316 TI
80 / 50	16	88.9	60.3	150	2.0	2.0	300	2.29	AISI 304	AISI 316 TI
80 / 40	16	88.9	48.3	150	2.0	2.0	300	2.17	AISI 304	AISI 316 TI
100 / 80	16	114.3	88.9	165	2.0	2.0	330	4.71	AISI 304	AISI 316 TI
100 / 65	16	114.3	76.1	165	2.0	2.0	330	3.94	AISI 304	AISI 316 TI
100 / 50	16	114.3	60.3	165	2.0	2.0	330	3.77	AISI 304	AISI 316 TI
100 / 40	16	114.3	48.3	165	2.0	2.0	330	3.64	AISI 304	AISI 316 TI
125 / 100	16	139.7	114.3	190	2.6	2.0	380	6.56	AISI 304	AISI 316 TI
125 / 80	16	139.7	88.9	190	2.6	2.0	380	5.44	AISI 304	AISI 316 TI
125 / 65	16	139.7	76.1	190	2.6	2.0	380	5.28	AISI 304	AISI 316 TI
150 / 125	16	168.3	139.7	210	2.6	2.6	420	8.54	AISI 304	AISI 316 TI
150 / 100	16	168.3	114.3	210	2.6	2.0	420	7.62	AISI 304	AISI 316 TI
150 / 80	16	168.3	88.9	210	2.6	2.0	420	6.84	AISI 304	AISI 316 TI
150 / 65	16	168.3	76.1	210	2.6	2.0	420	6.67	AISI 304	AISI 316 TI
150 / 50	16	168.3	60.3	210	2.6	2.0	420	6.47	AISI 304	AISI 316 TI
200 / 150	16	219.1	168.3	275	3.0	2.6	550	16.28	AISI 304	AISI 316 TI
200 / 125	16	219.1	139.7	275	3.0	2.6	550	14.46	AISI 304	AISI 316 TI
200 / 100	16	219.1	114.3	275	3.0	2.6	550	13.28	AISI 304	AISI 316 TI

Remarks:

- additional versions and dimensions are available on request (e.g. AISI 304 / AISI 316 L)

REDUCERS CONCENTRIC

welded DIN 2616 / EN 10253-4

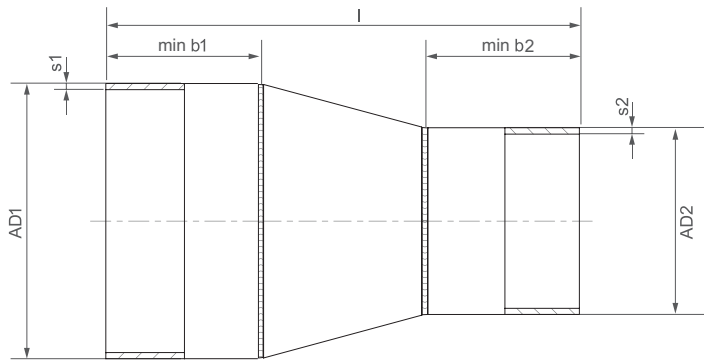

DN / DN	PN [bar]	OD 1 [mm]	OD 2 [mm]	s1 [mm]	s2 [mm]	l [mm]	Weight [kg/pce]	Material	Material
								V2A	V4A
65 / 50	16	76.1	60.3	2.0	2.0	225	1.08	AISI 304	AISI 316 TI
65 / 40	16	76.1	48.3	2.0	2.0	210	1.02	AISI 304	AISI 316 TI
80 / 65	16	88.9	76.1	2.0	2.0	245	1.33	AISI 304	AISI 316 TI
80 / 50	16	88.9	60.3	2.0	2.0	225	1.34	AISI 304	AISI 316 TI
80 / 40	16	88.9	48.3	2.0	2.0	210	1.29	AISI 304	AISI 316 TI
100 / 80	16	114.3	88.9	2.0	2.0	255	2.10	AISI 304	AISI 316 TI
100 / 65	16	114.3	76.1	2.0	2.0	255	1.87	AISI 304	AISI 316 TI
100 / 50	16	114.3	60.3	2.0	2.0	235	1.93	AISI 304	AISI 316 TI
125 / 100	16	139.7	114.3	2.6	2.0	287	3.14	AISI 304	AISI 316 TI
125 / 80	16	139.7	88.9	2.6	2.0	287	2.41	AISI 304	AISI 316 TI
125 / 65	16	139.7	76.1	2.6	2.0	287	2.59	AISI 304	AISI 316 TI
150 / 125	16	168.3	139.7	2.6	2.6	315	4.09	AISI 304	AISI 316 TI
150 / 100	16	168.3	114.3	2.6	2.0	300	3.89	AISI 304	AISI 316 TI
150 / 80	16	168.3	88.9	2.6	2.0	300	3.53	AISI 304	AISI 316 TI
150 / 65	16	168.3	76.1	2.6	2.0	300	3.45	AISI 304	AISI 316 TI
150 / 50	16	168.3	60.3	2.6	2.0	300	3.38	AISI 304	AISI 316 TI
200 / 150	16	219.1	168.3	3.0	2.6	342	7.15	AISI 304	AISI 316 TI
200 / 125	16	219.1	139.7	3.0	2.6	342	7.06	AISI 304	AISI 316 TI
200 / 100	16	219.1	114.3	3.0	2.0	327	6.61	AISI 304	AISI 316 TI

FLANGE ADAPTER

EN 1092-1

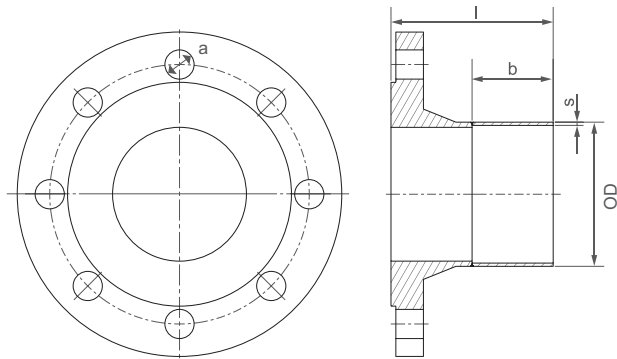

DN	PN [bar]	OD [mm]	a [mm]	b [mm]	s [mm]	l [mm]	Weight [kg/pce]	Material	Material
								V2A	V4A
32	16	42.4	4 x 18	60	2.6	100	2.11	AISI 321	AISI 316 TI
40	16	48.3	4 x 18	60	2.6	102	2.60	AISI 321	AISI 316 TI
50	16	60.3	4 x 18	80	3.0	125	3.32	AISI 321	AISI 316 TI
65	16	76.1	4 x 18	95	3.0	140	3.70	AISI 321	AISI 316 TI
80	16	88.9	8 x 18	95	3.2	145	4.53	AISI 321	AISI 316 TI
100	16	114.3	8 x 18	95	3.6	147	5.82	AISI 321	AISI 316 TI
125	16	139.7	8 x 18	110	4.0	165	8.21	AISI 321	AISI 316 TI
150	16	168.3	8 x 22	110	4.0	165	8.00	AISI 321	AISI 316 TI
200	16	219.1	12 x 22	150	4.0	212	12.50	AISI 321	AISI 316 TI
250	16	273.0	12 x 26	150	4.0	220	17.90	AISI 321	AISI 316 TI
300	16	323.9	12 x 26	150	4.0	228	23.40	AISI 321	AISI 316 TI

Remarks:

- additional versions and dimensions are available on request (e.g. AISI 304 / AISI 316 L)

PIPE END CAPS

DIN / EN

DN	PN [bar]	OD [mm]	b [mm]	s [mm]	l [mm]	Weight [kg/pce]	Material	
							V2A	V4A
15	16	21.3	14	2.0	50	0.06	AISI 304 L	AISI 316 TI
20	16	26.9	21	2.0	50	0.09	AISI 304 L	AISI 316 TI
25	16	33.7	23	2.0	50	0.13	AISI 304 L	AISI 316 TI
32	16	42.4	26	2.0	60	0.19	AISI 304 L	AISI 316 TI
40	16	48.3	30	2.0	60	1.48	AISI 304 L	AISI 316 TI
50	16	60.3	38	2.0	80	0.45	AISI 304 L	AISI 316 TI
65	16	76.1	43	2.0	90	0.53	AISI 304 L	AISI 316 TI
80	16	88.9	45	2.0	90	0.71	AISI 304 L	AISI 316 TI
100	16	108.0	45	2.0	90	0.93	AISI 304 L	AISI 316 TI
100	16	114.3	45	2.0	90	0.99	AISI 304 L	AISI 316 TI
125	16	139.7	48	2.6	100	1.70	AISI 304 L	AISI 316 TI
150	16	168.3	48	2.6	100	2.15	AISI 304 L	AISI 316 TI
200	16	219.1	62	3.0	140	3.75	AISI 304 L	AISI 316 TI

THREADED CONNECTION (outside)

DIN / EN

DN	G [Inch]	OD [mm]	g [mm]	b [mm]	s [mm]	l [mm]	Weight [kg/pce]	Material	
								V2A	V4A
15	½ "	21.3	13	47	2.65	60	0.07	AISI 304 L	AISI 316 TI
20	¾ "	26.9	15	45	3.25	60	0.12	AISI 304 L	AISI 316 TI
25	1 "	33.7	17	43	3.25	60	0.15	AISI 304 L	AISI 316 TI
32	1 ¼ "	42.4	19	61	3.25	80	0.21	AISI 304 L	AISI 316 TI
40	1 ½ "	48.3	19	61	3.25	80	0.33	AISI 304 L	AISI 316 TI
50	2 "	60.3	24	76	3.65	100	0.51	AISI 304 L	AISI 316 TI
65	2 ½ "	76.1	27	93	3.65	120	0.79	AISI 304 L	AISI 316 TI
80	3 "	88.9	30	95	4.05	125	1.08	AISI 304 L	AISI 316 TI
100	4 "	114.3	36	94	4.50	130	1.61	AISI 304 L	AISI 316 TI



STAINLESS STEEL PIPE

welded, unannealed EN 10217-7

DN	PN [bar]	OD [mm]	s [mm]	l [mm]	Weight		Material	
					[kg / m]	[kg / 6 m]	V2A	V4A
50	16	60.3	2.0	6	2.92	17.52	AISI 304	AISI 316 TI
65	16	76.1	2.0	6	3.71	22.26	AISI 304	AISI 316 TI
80	16	88.9	2.0	6	4.35	26.10	AISI 304	AISI 316 TI
100	16	114.3	2.0	6	5.62	33.72	AISI 304	AISI 316 TI
125	16	139.7	2.6	6	8.93	53.58	AISI 304	AISI 316 TI
150	16	168.3	2.6	6	10.79	64.74	AISI 304	AISI 316 TI
200	16	219.1	3.0	6	16.23	97.38	AISI 304	AISI 316 TI

Remarks:

- additional versions and dimensions are available on request (e.g. AISI 304 / AISI 316 L)

FOR A SAFE CONNECTION

STRAUB ACCESSORIES

- Strip inserts
- Stiffening rings
- Torque wrench & inserts
- Anti-seize compound & lubricating grease
- OPEN-FLEX fitting tool
- Long catch bolt
- Tensioning Strap
- Rubber hammer
- FLEX sealing sleeves
- Lock parts
- Earthing conductor
- Thrust protectors / tie rods



STRIP INSERTS

Strip inserts protect the sealing sleeve against mechanical or chemical damage in the pipe end area.

Strip inserts are required for:

- Excessive distance between pipe ends
- Axial movement (expansion, contraction)
- Angular deflection and axial misalignment
- Vacuum (e.g. suction line)
- External pressure (e.g. underwater pipeline)
- High temperature
- Fuel and combustibles
- Swelling of the rubber caused by contact with chemicals

The material selection is determined by the medium and the temperature. At environmental temperatures, with salt water and chemicals, strip inserts in plastic are used. Stainless steel strip inserts are required for higher temperatures, vacuum and external pressure. Combinations of plastic and stainless steel are also possible. T-profile strip inserts ensure the installation position where there are strong and dynamic loads.

Temperature ranges:

- PVDF-30°C up to +115°C
- HDPE-50°C up to +70°C

Strip inserts can also be installed at a later date with STRAUB pipe couplings.

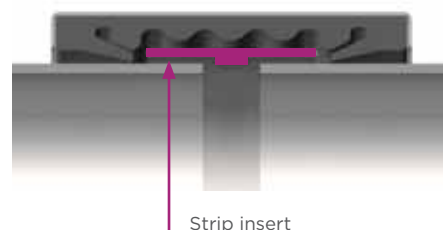

STRAUB pipe coupling	Stainless steel		Plastic		Plastic-T-Profile *	
	AISI 316 L or similar	AISI 301	PVDF	HDPE	PVDF	HDPE
STRAUB-METAL-GRIP	x		x			
STRAUB-GRIP 25.0-168.3 mm	x		x			
STRAUB-GRIP-L 180.0-711.2 mm	x			x		
STRAUB-ECO-GRIP	x					
STRAUB-PLAST / COMBI-GRIP	x		x			
STRAUB-FLEX / OPEN-FLEX 1	x		x		X (from 76.1mm)*	
STRAUB-FLEX / OPEN-FLEX 2	x			x		x *
STRAUB-FLEX / OPEN-FLEX 3	x			x		x *
STRAUB-FLEX / OPEN-FLEX 3.5		x		x		
STRAUB-FLEX / OPEN-FLEX 4		x		x		

* T-Profile	OD [mm]	Strip width a [mm]	cam width b [mm]	cam height c [mm]
STRAUB-FLEX / OPEN-FLEX 1	76.1 - 118.0 mm	45	5	3.5
	127.0-168.3 mm	55	5	3.5
STRAUB-FLEX / OPEN-FLEX 2	all OD	75	7.5	6
STRAUB-FLEX / OPEN-FLEX 3	all OD	118	10	6

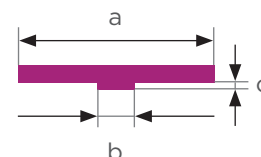

STIFFENING RINGS

Thermoplastic pipes can be deformed under the influence of pressure and heat.

Through the use of STRAUB stiffening rings, a constriction of the plastic pipe ends is prevented.

STRAUB stiffening rings consist of stainless steel DIN 1.4301/AISI 304 and are available in slotted (OD 40 - 315mm) and welded designs (OD 355 - 1600 mm). One of the following may be required:

- Inside diameter
- SDR number
- Wall thickness of the plastic pipe

Connecting plastic pipes requires the use of stiffening rings

If the pipes already exhibit constriction due to long storage, we recommend cutting off these constricted sections before fitting the STRAUB stiffening rings. Slotted stiffening rings must be fitted in the direction of the arrow marked and installed flush with the pipe end.



Note:

For plastic pipes in PVC, ABS and CPVC, and with fibreglass pipes, no stiffening rings are required for media temperatures under 40°C.

Table for choosing the STRAUB-PLAST-GRIP stiffening ring

SDR	41	33 / 32.25	26	17.6	17	11	7.4 / 7.25
Serie-Nr.	S 20	S 16 / S 15.625	S 12.5	S 8.3	S 8	S 5	S 3.2 / S 3.125
Norm	DIN 8074	DIN 8074	DIN 8074	DIN 8074	DIN 8074	DIN 8074	DIN 8074
Pipe OD	Pipe ID	Pipe ID	Pipe ID	Pipe ID	Pipe ID	Pipe ID	Pipe ID
OD [mm]	[mm]	[mm]	[mm]	[mm]	[mm]	[mm]	[mm]
40	-	-	36.4	35.4	35.2	32.6	29
50	-	46.4	46.0	44.2	44.0	40.8	36.2
63	59.4	59.0	58.0	55.8	55.4	51.4	45.8
75	71.2	70.4	69.2	66.4	66.0	61.4	54.4
90	85.6	84.4	83.0	79.8	79.2	73.6	65.4
110	104.6	103.2	101.6	97.4	96.8	90.0	79.8
125	118.8	117.2	115.4	110.8	110.2	102.2	90.8
140	133.0	131.4	129.2	124.0	123.4	114.6	101.6
160	152.0	150.2	147.6	141.8	141.0	130.8	116.2
180	171.2	169.0	166.2	159.6	158.6	147.2	130.8
200	190.2	187.6	184.6	177.2	176.2	163.6	145.2
225	214.0	211.2	207.8	199.4	198.2	184.0	163.4
250	237.6	234.6	230.8	221.6	220.4	204.6	181.6
280	266.2	262.8	258.6	248.2	246.8	229.2	203.4
315	299.6	295.6	290.8	279.2	277.6	257.8	228.8

Remarks:

- Choosing stiffening rings owing to measurements on pipes only conditionally possible
- Valid only to soft thermoplastic pipes f.e. PE, PP, etc.
- Stiffening rings are optional accessories and has to be ordered separately.

TORQUE WRENCH AND INSERTS

To ensure successful use of STRAUB couplings, a torque wrench must be used.

The scale of the torque wrench is marked in Nm and lbft.



The following torque wrenches cover the range of STRAUB pipe couplings:

[Nm]	Torque range		Article
		[lbft]	
5 - 25		3.7 - 18.5	11028
20 - 100		14.5 - 73.5	11031
40 - 200		14.5 - 147.5	11033
60 - 300		44.0 - 221.0	11034

½" short and long allen wrench

Allen key short ¹⁴	Allen head [mm]	Article
	5	7264
	6	1453
	8	1434
	10	1454
	14	1455
	17	1456

Allen key long ¹⁵	Allen head [mm]	Article
	5	-
	6	2611
	8	7265
	10	7266
	14	7267
	17	100197

Inserts for ½" allen bolts

Allen key ¹⁶	Allen head [mm]	Article
	17	100036
	19	100032

¹⁴ for pipes OD up to 1000 mm

¹⁵ for pipes OD bigger than 1000mm

¹⁶ for STRAUB-CLAMP and STRAUB-REP-FLEX



ANTI-SEIZE COMPOUND FOR PIPE SURFACES AND THE COUPLING CASING

Lubricant is applied to the inside of the coupling housing during the manufacture of STRAUB pipe couplings. This allows an even distribution of the sleeve in the coupling housing.

For large and two-part pipe couplings, the lubricant must, however, be applied on site before installation, as the housing and the sleeve of the pipe coupling for these sizes are delivered separately. We recommend applying the lubricant with a sponge or a brush.



art. 5825

The use of anti-seize compound on the pipe surfaces has a positive effect in the contact area for the sleeve sealing lips for fitting and the distribution of rubber in the coupling housing.

The STRAUB anti-seize compound has a thick consistency and can therefore be used under all weather-conditions.

The amount required is dependent on the properties of the pipe surface to be treated. For example, for two pipe ends of a fibreglass pipe with OD 2000 mm, we recommend 1 kg of STRAUB anti-seize compound.

The STRAUB anti-seize compound for pipe surfaces is available in 3 kg tins (article 5825).

Pipe size / Pipe surface	STRAUB anti-seize compound
Pipes from an outside diameter of 406.0 mm	4 (required)
Rough, uneven and heavily corroded pipe surfaces: <ul style="list-style-type: none"> ▪ concrete ▪ cast iron ▪ asbestos cement ▪ GRP etc. 	4 (required)
Pipes with an outside diameter between 170.0 - 406.0 mm	4 (recommended)
Smooth, level and clean pipe surfaces: <ul style="list-style-type: none"> ▪ PE ▪ PP ▪ PVC ▪ vitrified clay ▪ stainless steel etc. 	(not required)
Pipes with an outside diameter between 26.9 - 168.3 mm (e.g. galvanised pipes)	(not required)

⇒ Anti-seize compound with NSF61 approval is available on request

LUBRICATING GREASE FOR LOCK BOLTS

Galvanised lock bolts for STRAUB pipe couplings are treated with a special lubricating grease. Rustproof lock bolts are covered in a molybdenum disulphide layer and thus need no special, additional treatment.

On disassembly and reuse of a STRAUB pipe coupling, however, both the galvanised and the stainless-steel lock bolts must be greased in order to prevent a “cold weld” of the bolts in the locking pins.

The lubricating grease for the lock bolts is available in 100 ml tubes (article 5819).



art. 5819

STRAUB-OPEN-FLEX FITTING TOOL

For the installation STRAUB-OPEN-FLEX pipe couplings are opened and put around the pipe. As a result the tension is relieved in the cut sleeve and is always longer than the pipe circumference - *do not cut shorter!*

To achieve perfect sealing, the sleeve must be pressed with a certain amount of force. In the process, the sleeve presses on the metal bridge of the pipe coupling and thus makes it difficult to easily reinsert the locking bolts. This pressing force can be applied easily and effort-savings with the STRAUB OPEN-FLEX (article 6649) assembly tool.

After retightening the lock bolts, these can be tightened further with an Allen wrench until the specified torque is achieved.



art. 6649

- Can be used for all OPEN-FLEX 1 + 2 couplings
- Space-saving (detachable handle)
- Design is suitable for use on site
- Access holes in the plates of the couplings

LONG CATCH BOLT

Long catch bolts help installing the STRAUB-OPEN-FLEX 2, 3, 3.5, and 4 types and can be reused.

A standard lock bolt is replaced on-site by a so-called long catch bolt (ideally in the middle of the lock). This has a cylindrical chamfer that forces the alignment of the lock bolt. The pipe coupling is now tensioned with the inserted long catch bolt until the standard lock bolt can be threaded into the threaded bolt. Afterwards, the long catch bolt must be removed and replaced by the standard lock bolt removed at the beginning.



art. 5943P1 (M10), 5943P2 (M12),
5943P3 (M16), 5943P4 (M20)

The long catch bolts are available in thread sizes M10, M12, M16 and M20.

TENSIONING STRAP

Tensioning straps making fitting of one and two-part STRAUB-OPEN-FLEX pipe couplings easier.

For lock openings of 210 mm and greater, we recommend the use of a tensioning strap without ratchet (article 5561: strap width 25 mm, length approx. 1.6m) for one-part STRAUB-OPEN-FLEX pipe couplings. When fitting STRAUB-OPEN-FLEX 3, 3.5 and 4, with pipe diameters of up to 3'000 mm, larger tensioning straps with a ratchet are necessary (article 5559: strap width 35 mm, length approx. 10 m).



art. 5561 (<210 mm)
art. 5559 (up to OD 3000 mm)

For smaller lock openings, the STRAUB-OPEN-FLEX assembly tool is suitable.

RUBBER HAMMER

With larger, two-part STRAUB-FLEX and STRAUB-OPEN-FLEX pipe couplings, an even distribution of the rubber sleeve in the housing is very important. To ensure this, a rubber or plastic hammer must be used to knock heavily on the coupling hous-

ing during the tensioning process around the entire circumference. This triggers a “slip-stick” process between the pipe surface and the sleeve, which leads to the desired rubber distribution.

FLEX SEALING SLEEVES

For STRAUB-FLEX pipe couplings, the sleeves themselves can be replaced if required. The following information is required for a delivery:

- STRAUB-FLEX coupling type
- Cutted or vulcanized version
- Coupling or pipe outside diameter
- Sealing sleeve material (EPDM, NBR, FPM/FKM)

Before fitting a new sealing collar, the inside of the casing must be treated with lubricant.

Note:

When installing a new sealing collar, the lock must also be replaced!

The sleeves for STRAUB-GRIP pipe couplings may not be replaced.

LOCK PARTS

Locks for all STRAUB pipe couplings are available as replacement parts. When ordering, information on the coupling type and size, as well as the material of the lock (galvanised or stainless steel) are required.

Locks for pipe couplings are only supplied as a complete unit.

Note:

The high-quality lock bolts may not be replaced by conventional standard bolts available commercially.

A lock set includes the following elements:

- Threaded bolts
- Drilled bolts
- Lock bolts
- Washers (only for locks in stainless steel)



EARTHING CONDUCTOR

STRAUB-FLEX and STRAUB-OPEN-FLEX pipe couplings have, in contrast to STRAUB-GRIP pipe couplings, no electrical conductivity and are thus insulating connections. An electrical bridge from pipe to pipe can, however, be established as required using metallic earth conductors that are inserted into the pipe coupling.

In this way, the STRAUB earth connector replaces an external cable bridge.

Our earthing conductor system has been tested by the SEV (Swiss Association for Electrical Engineering, Power and Information Technologies) on the basis of SEV 04 ATEX 0167 (EN 1127-1:2007 and EN 13463-1:2009)*.

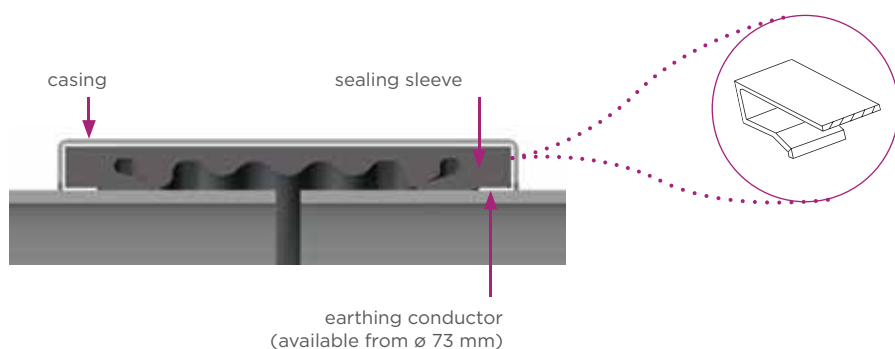

ADVANTAGES

- Explosion protection (prevents static charging)
- Corrosion protection
- Electrically conductive connection between metallic pipes
- Earthing for cable conduits

*The ATEX name refers to the French abbreviation for "Atmosphère explosive" and is used as a synonym for the directives of the European Union in the field of explosion protection.

THRUST PROTECTORS / TIE RODS

Axial thrust protectors/tie rods are used together with STRAUB-FLEX applications and are designed to accept axial tensile forces.

Any calculations, design and supply are provided by STRAUB.



STRAUB: WELL-PROVEN QUALITY PRODUCTS

Made in Switzerland		
straub  <i>the right connection</i> Tel. +41 81 725 41 00 straub@straub.ch www.straub.ch		
	-	PN 2.5 bar
	-	58 psi
FLEX 3 Ø 2400.0 mm 94.488 inch		 W5
Art.No. 658062 not pull-out-resistant	Ser.No. 109792020915 SEE ASSEMBLY INSTRUCTIONS	
		
135 Nm [100 lb.ft]	EPDM	15 mm

Approval-related nominal pressure (e.g. shipbuilding)

Working pressure [bar]

Working pressure [psi]

QR Code (fitting instruction)

Material class

STRAUB article | Serial No.

Information (not) pull-out-resistant

Pipe gap without strip insert

Sealing sleeve
Torque rate

STRAUB

INSTALLATION INSTRUCTIONS

A unique principle, but countless possible applications. Cost effectiveness and reliability, also under the harshest conditions, are our top priorities.

Correct application is the prerequisite to be able to utilise all advantages of the STRAUB technology.

PIPE GAP [R]

A space between pipe ends can arise through misalignment, ground movement, inaccurate assembly or changes in length. STRAUB couplings can bridge spaces between pipe ends.

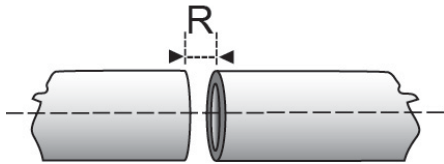

- 5 - 10 without strip insert (depending on pipe OD, please observe the coupling label!)
- 5 - 35 mm with strip insert (depending on pipe OD, please observe techn. data sheet!)



Strip inserts are used in case of: large distance between pipe ends, swelling due to aggressive liquids, vacuum, under outside pressure, high temperature. Strip inserts are extras and must be ordered separately.

Do not exceed the listed pipe gap; further information see page 104.

ANGULAR DEFLECTION [α]

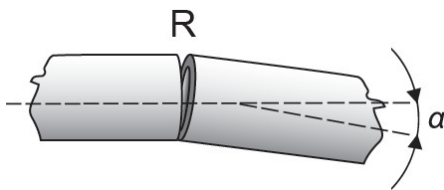

STRAUB couplings to connect two pipes with all around angular deflection to the pipe axis:

- $< \varnothing 60.3 \text{ mm} \Rightarrow 5^\circ$
- $> \varnothing 76.1 \text{ mm} \Rightarrow 4^\circ$
- $> \varnothing 219.1 \text{ mm} \Rightarrow 2^\circ$
- $> \varnothing 609.6 \text{ mm} \Rightarrow 1^\circ$

\Rightarrow See distance between pipe ends [R]!

LINEAR MISALIGNMENT

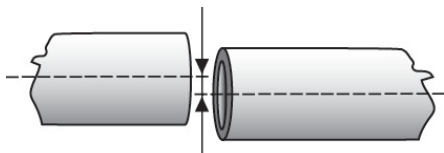

STRAUB pipe couplings allow a low axial misalignment:

- 1% of outside diameter (max. 3 mm)

OUTSIDE DIAMETER DIFFERENCE

STRAUB couplings compensate pipes with different outside diameters. The following requirements must be satisfied:

- $< \varnothing 100 \text{ mm}$ \Rightarrow 2 mm
 - $> \varnothing 100 \text{ mm}$ \Rightarrow 2%
 - $> \varnothing 300 \text{ mm}$ \Rightarrow 6 mm
-
- OD-difference up to 9 mm \Rightarrow STRAUB-FLEX
 - OD-difference from 10 mm \Rightarrow STRAUB-STEP-FLEX

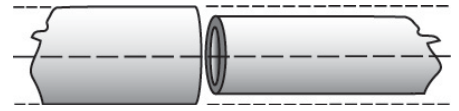

PIPES OUT OF ROUNDNESS

Pipes often show an un out-of-roundness (difference between the biggest and the smallest outside diameter). The reliable out of roundness is:

- STRAUB-FLEX 1 \Rightarrow 4 mm
- STRAUB-FLEX 2 \Rightarrow 2% of \varnothing
- STRAUB-FLEX 3 \Rightarrow 2% of \varnothing
- STRAUB-FLEX 3.5 \Rightarrow 2% of \varnothing
- STRAUB-FLEX 4 \Rightarrow 2% of \varnothing

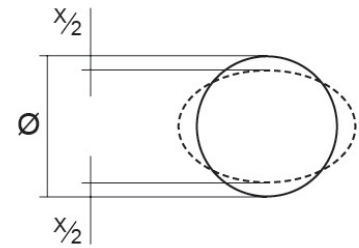

STRAUB-FLEX 2 - 4:

To provide over-slide possibility, out-of-roundness [X] has also to be within the admissible \varnothing -difference ($X = \text{max. } 6 \text{ mm}$).



AXIAL TENSILE FORCE [F_A]

The PN internal pressure acts directly as tensile force on every pipe connection. The prevailing tensile force can be calculated from the respective internal pressure and the known pipe diameter.

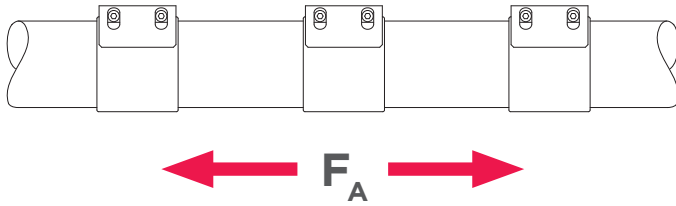

It cannot be absorbed by STRAUB-FLEX and STRAUB-OPEN-FLEX.

AXIAL COLLAPSING FORCE [F_K]

If the pipes are obstructed in their axial movement, the pipe has the tendency to buckle in the case of increasing internal pressure in combination with inadequate pipe routing.

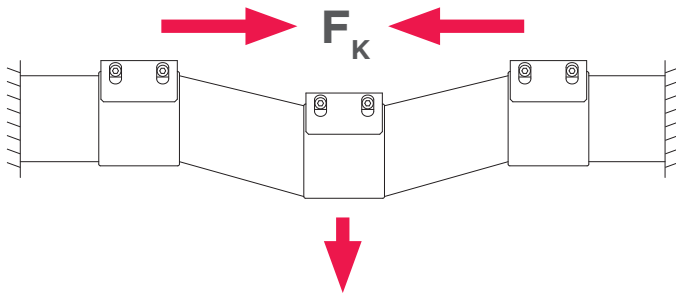

It cannot be absorbed by STRAUB-FLEX and STRAUB-GRIP.

RADIAL WEIGHT [F_R]

This consists of the weight of the pipe section and the weight of the medium contained in it. Pipe couplings can only absorb very small shear forces. In the case of doubt, contact STRAUB directly.

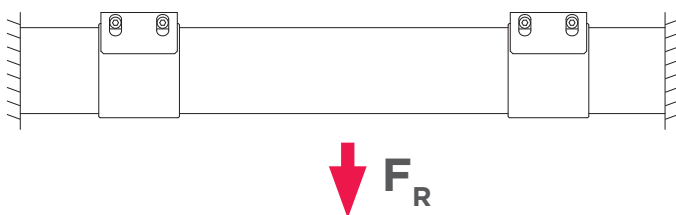

It can only be absorbed to a limited extent by STRAUB-FLEX and STRAUB-GRIP.

Loads
and
operating conditions

AXIAL MOVEMENT | DILATATION

Pipes are exposed to temperature fluctuations whether from the medium (e.g. cold and warm water) or the environment (e.g. sunlight, cold in winter). These temperature fluctuations cause axial movements in the pipe.

The axial movement depends on the pipe material, the length of the respective pipe section and the temperature fluctuation.

When using STRAUB-GRIP pipe couplings, the pipe fastenings are selected so that the axial movement is transformed to angular deflection.



If STRAUB-FLEX pipe couplings are used, it must be ensured that the occurring axial change in each pipe section is not greater than the compensation capability of the used STRAUB-FLEX pipe coupling.

Attention:
A fixed point and at least one sliding pipe restraint are required for each individual pipe section.

Reaction forces for STRAUB-FLEX:

Ø [mm]	101.6	168.0	219.1	355.6	558.8	812.8
Newton [N]	3800	4800	5600	7300	9800	12500



Compensation of the axial movement

If the operating temperature is higher than the installation temperature, this results in elongation of the pipe. In contrast, the pipe contracts if it is lower than the installation temperature.

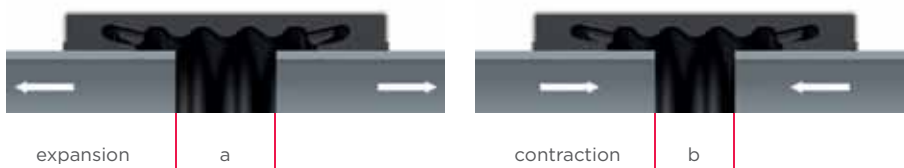

Max. permissible axial length change:

STRAUB-FLEX STRAUB-OPEN-FLEX	Δl (a-b) [mm]
1	5
2	10
3	15
3.5	15
4	20

PIPE FASTENING USING:

STRAUB-GRIP

AXIAL RESTRAINT

- The pipes are anchored in the coupling
- Only mounts / supports are necessary
- Axial movements of the pipes must be compensated for outside the coupling, e.g. with expansion arches (see ①) or changing into angular deflection (see ②)

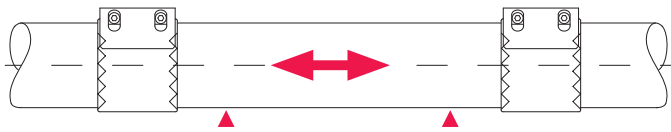

STRAUB-FLEX

NON-AXIAL RESTRAINT

- The pipes are not anchored in the coupling
- Every pipe section needs one fixed point and one or more pipe guides
- Axial movements of the pipes can be compensated for within the coupling (see page 50)

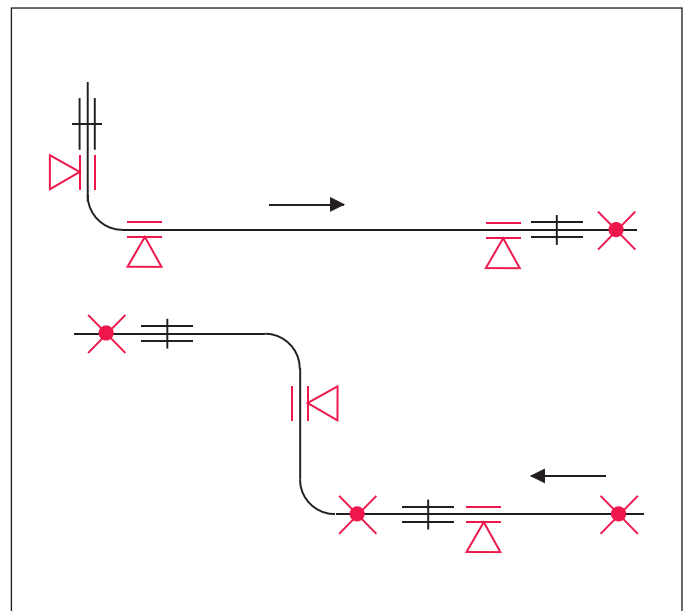
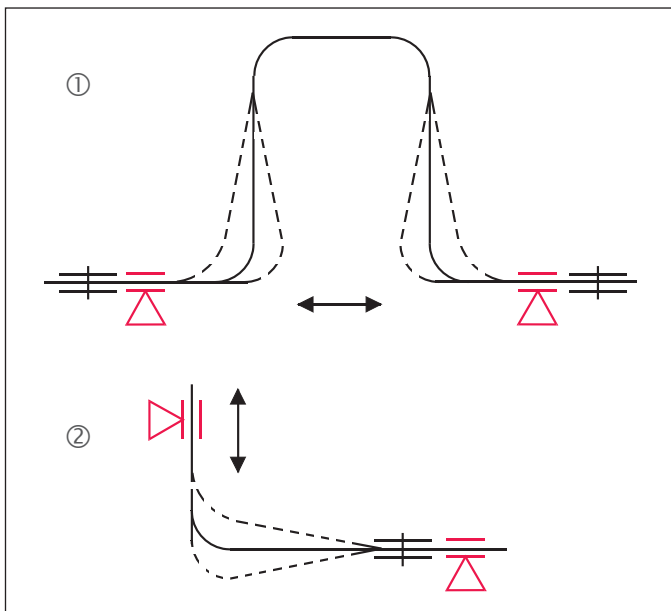
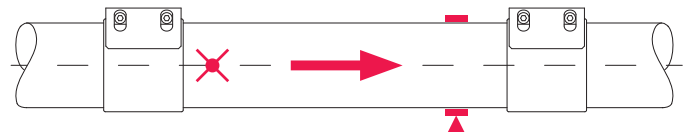

≡ STRAUB-GRIP pipe coupling

≡ Sliding pipe guide
axially unrestricted

≡ STRAUB-FLEX pipe coupling

✗ Anchor point
For accepting the STRAUB-FLEX coupling stress and the stress resulting from internal force



SUCCESSFULLY «**STRAUBING**»

The correct coupling type at the right place!

The STRAUB pipe connection technology is regarded as an easy, simple and quick to implement system in piping construction.

39,5

WE PROVIDE COMPETENCE **IN ALL DESIGNS**

The use of STRAUB pipe couplings is impressive due to practically tested reliability and consistent cost effectiveness.



DIMENSIONS TABLE FOR PRESSURE PIPES

Pipe DN	Ductile cast iron DIN 28610 [mm]	Old cast iron [mm]	Cast iron DIN 2431			Steel			PVC DIN 8062 [mm]	PE DIN 8074 [mm]	AZ DIN 19800					
			PN 8 PN 16	PN 25 [mm]	PN 40	Threaded pipe	Boiler pipe [mm]	Plug-in sleeve +4mm PE			PN 10		PN 12.5		PN 16	
											cal.	uncal.	cal.	uncal.	cal.	uncal.
32		42-43	46			42.4	44.5		40	40						
40	56	51-53	56			48.3	51.0		50	50						
50	66	62-64	66	67	70	60.3	70.0		63	63						
60		72-74	77	78	82											
65	85		77	78	82	76.1			75	75			83		85	
(75)		88-91	87	89	92											
80	98	94-96	98	100	104	88.9	88.9		90	90	98	102	100		104	
(90)		104-108	108	112	116											
100	118	114-116	118	122	128	114.3	108.0	117.5	110/125	110/125	120	128	124		130	
125	144	140-143	144	149	155	139.7	133.0	144.0	140	140	149	154	153		159	
150	170	166-169	170	176		168.3	159.0	168.3	160/180	160/180	178	184	182		190	
175		191-194	196	203	213	193.7	191.0									
200	222	218-222	222	230	242	219.1	216.0	219.1	200/225	200/225	234	243	240		252	
225		244-247	248	259	271	229.1	241.0									
250	274	268-273	274	286	298	273.0	267.0	273.0	250/280	250/280	286	288	296		308	
275		397-300	300	313	327		292.0									
300	326	322-325	326	340	358	323.9	318.0	323.9	315	315	342	346	352		368	
325		348-352	352	367	385		343.0		355	355						
350	378	376-379	378	394	412	355.6	368.0		400	400		404	410		428	
375			403	421	441											
400	429	426-430	429	448	470	406.4	419.0		450	450	456	460	470		488	
450	480	476-480	480	504		457.0				500	510		524		546	
500	532	527-530	532	558		508.0			560	560	564		582		606	
550		581-585	583						630	630						
600	635	631-635	634			610.0			710	710	678		698		726	
650			686			660.4										
700	738		738			711.2			800	800		792				
750			790			762.0										
800	842		842			812.8			1000	100						
900	945		945			914.4										
1000	1048		1048			1016.0			1200	1200		1125				

PIPE GAP BETWEEN PIPE ENDS DUE TO ANGULAR DEFLECTION α

Gaps between pipe ends are created by angular deflection, inaccurate assembly and changes in length. This gap must not exceed the value R (R = pipe end gap / may be obtained from product datasheet).

Using a strip insert (also refer to page 87), the pipe and gap can be enlarged. This maximum value depends on the design of each coupling type and may be obtained from the relevant product datasheet.

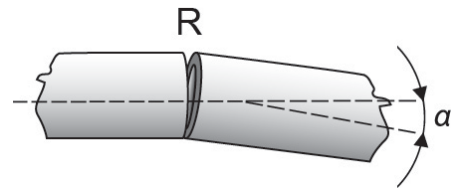

OD [mm]	α in degrees							
	1	2	4	6	8	10	12	
	R_{max} [mm]			R_{max} [mm]				
26.9	0.5	1	2	3	4	5	6	
30.0	0.5	1	2	3	4	5	6	
33.7	0.5	1	2	3	4	6	7	
38.0	1	1	3	4	5	7	8	
40.0	1	2	3	4	6	7	8	
42.4	1	2	3	4	6	7	9	
44.5	1	2	3	5	6	8	9	
48.3	1	2	3	5	7	8	10	
50.0	1	2	4	5	7	9	11	
54.0	1	2	4	6	8	9	11	
57.0	1	2	4	6	8	10	12	
60.3	1	2	4	6	8	11	13	
63.0	1	2	4	7	9	11	13	
75.0	1	3	5	8	11	13	16	
76.1	1	3	5	8	11	13	16	
84.0	2	3	6	9	12	15	18	
88.9	2	3	6	9	12	16	19	
90.0	2	3	6	9	13	16	19	
104.0	2	4	7	11	15	18	22	
108.0	2	4	8	11	15	19	23	
110.0	2	4	8	12	15	19	23	
114.3	2	2	8	12	16	20	24	
125.0	2	2	9	13	17	22	26	
129.0	2	5	9	14	18	23	27	
133.0	2	5	9	14	19	23	28	
139.7	2	5	10	15	20	24	29	
140.0	2	5	10	15	20	24	29	
154.0	3	5	11	16	22	27	32	
159.0	3	6	11	17	22	28	33	
160.0	3	6	11	17	22	28	33	
168.3	3	6	12	18	24	30	35	

OD [mm]	α in degrees					
	1	2	3	4	6	8
	R_{max} [mm]			R_{max} [mm]		
180.0	3	6	9	13	19	25
200.0	4	7	11	14	21	28
219.1	4	8	12	15	23	31
244.5	4	9	13	17	26	34
250.0	4	9	13	17	26	35
267.0	5	9	14	19	28	37
273.0	5	10	14	19	29	38
304.0	5	11	16	21	32	42
323.9	6	11	17	23	34	45
355.6	6	12	19	25	37	50
406.4	7	14	21	28	43	57
457.2	8	16	24	32	48	
508.0	9	18	27	36	53	
559.0	10	20	29	39	59	
575.0	10	20	30	40		
609.6	11	21	32	43		
711.2	12	25	37	50		
762.0	13	27	40	53		
812.8	14	28	43	57		
914.4	16	32	48			
1016.0	18	36	53			
1117.6	20	39	59			
1219.2	21	43				
1320.8	23	46				
1422.4	25	50				
1524.0	27	53				
1625.6	28	57				
1727.2	30					
1828.8	32					
1930.4	34					
2032.0	36					

DIMENSIONS AND MINIMUM WALL THICKNESS AT NOMINAL PRESSURE PN

Pipe OD		Nominal diameter		Min. wall thickness		
Metric [mm]	IPS [inch]	Metric [DN]	IPS [Nom]	Stainless steel STRAUB-METAL-GRIP STRAUB-GRIP GRIP-L STRAUB-ECO-GRIP [mm]	CuNi10Fe (DIN) CuNi10Mn1Fe (ISO) STRAUB-GRIP GRIP-L STRAUB-ECO-GRIP [mm]	
21.3	0.840	15	½	1.5	1.5	
26.9	1.050	20	¾	1.5	1.5	
30.0	1.180	25	1.2	1.5	1.5	
33.7	1.325	25	1	1.5	2.0	
38.0	1.495	32	1.5	1.5	2.0	
42.4	1.670	32	1 ¼	1.5	2.0	
44.5	1.750	40	1.75	1.5	2.0	
48.3	1.900	40	1 ½	1.5	2.0	
50.8	2.000			2.0	2.0	
54.0	2.125	50	2.125	2.0	2.0	
57.0	2.245	50	2.25	2.0	2.0	
60.3	2.375	50	2	2.0	2.0	
66.6	2.625	65	2 ½	2.0	2.0	
70.0	2.756	65	2 ½	2.0	2.0	
73.0	2.875	65	2 ½	2.0	2.0	
76.1	(3.000)	65	(3 O.D.)	2.0	2.0	
79.5	3.125	65	3	2.0	2.0	
84.0	3.305	80	3.3	2.0	2.0	
88.9	3.500	80	3	2.0	2.0	
100.6	3.960	90	(3)	2.0	2.3	
101.6	(4.000)	100	(3 ½)	2.0	2.3	
104.0	4.095	100	4.1	2.0	2.3	
104.8	4.125	100	(4)	2.0	2.3	
108.0	4.250	100	4 ¼	2.0	2.3	
114.3	4.500	100	4	2.0	2.3	
127.0	5.000	100	4 ½	2.6	3.0	
129.0	5.080	125	5	2.6	3.0	
130.2	5.125	125	(5)	2.6	3.0	
131.0 ¹⁷				3.0		
133.0	5.235	125	5 ¼	2.6	3.0	
139.7	(5.500)	125	(5 ½)	2.6	3.0	
141.3	5.565	125	5	2.6	3.0	
154.0	6.065	150	6.1	2.6	3.0	
155.0 ¹⁷				2.5		
159.0	6.260	150	6 ¼	2.6	3.0	
168.3	6.625	150	6	2.6	3.5	
193.7	7.625	200	7.6	3.0	3.5	
206.0 ¹⁷				3.0		
219.1	8.625	200	8	3.0	3.5	
244.5	9.625	225	9	on request	on request	4.5
256.0 ¹⁷				on request	on request	
267.0	10.510	250	10.5	on request	on request	4.5
273.0	10.750	250	10	on request	on request	5.0
306.0 ¹⁷				on request	on request	
323.9	12.750	300	12	on request	on request	5.5
355.6	14.000	350	14	on request	on request	6.0
406.4	16.000	400	16	on request	on request	8.0
457.2	18.000	450	18	on request	on request	9.0
508.0	20.000	500	20	on request	on request	10.0
558.8	22.000	550	22	on request	on request	10.0
609.6	24.000	600	24	on request	on request	12.0
711.2	28.000	700	28	on request	on request	on request

Thinner walls are possible at lower pressures. Contact the STRAUB Application Technology department for other pipe diameters, different pipe materials and pressure values and smaller pipe wall thicknesses.

¹⁷ Standard pipe dimension for stainless steel (OD related to the wall thickness)

ASSEMBLY SET-UP TIME AND DIMENSION COMPARISON

The installation time includes:

- Marking of half the coupling width on both pipe ends
- Fitting the coupling over pipe ends and correct alignment
- Tightening the bolts with a torque wrench

Pipe OD		Nominal diameter		Installation time per coupling [min]
Metric [mm]	IPS [inch]	Metric [DN]	IPS [Nom]	
21.3	0.840	15	½	2
26.9	1.050	20	¾	2
30.0	1.180	25	1.2	2
33.7	1.325	25	1	2
38.0	1.495	32	1.5	2
42.4	1.670	32	1 ¼	2
44.5	1.750	40	1.75	2
48.3	1.900	40	1 ½	2
54.0	2.125	50	2.125	3
57.0	2.245	50	2.25	3
60.3	2.375	50	2	3
66.6	2.625	65	2 ½	4
73.0	2.875	65	2 1/2	4
76.1	(3.000)	65	(3 OD)	4
79.5	3.125	65	3	4
84.0	3.305	80	3.3	4
88.9	3.500	80	3	4
100.6	3.960	80	(3)	5
101.6	(4.000)	90	(3 ½)	5
104.0	4.095	100	4.1	5
104.8	4.125	100	(4)	5
108.0	4.250	100	4 ¼	5
114.3	4.500	100	4	5
127.0	5.000	100	4 ½	6
129.0	5.080	125	5	6
130.2	5.125	125	(5)	6
133.0	5.235	125	5 ¼	6
139.7	(5.500)	125	(5 ½)	6
141.3	5.565	125	5	6
154.0	6.065	150	6.1	7
159.0	6.260	150	6 ¼	7
168.3	6.625	150	6	7
219.1	8.625	200	8	9
244.5	9.625	225	9	10
267.0	10.510	250	10.5	10
273.0	10.750	250	10	10
323.9	12.750	300	12	12
355.6	14.000	350	14	12
406.4	16.000	400	16	12
457.2	18.000	450	18	12
508.0	20.000	500	20	12
558.8	22.000	550	22	12
609.6	24.000	600	24	12
711.2	28.000	700	28	12

MATERIAL SPECIFICATIONS OF STRAUB COUPLINGS

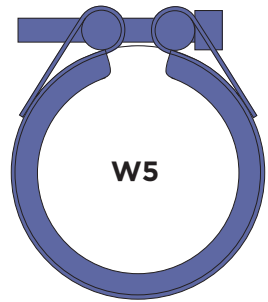
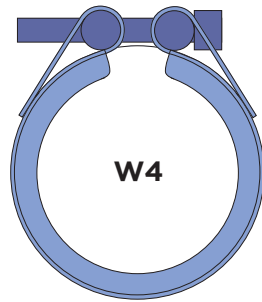
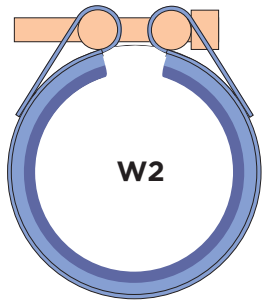
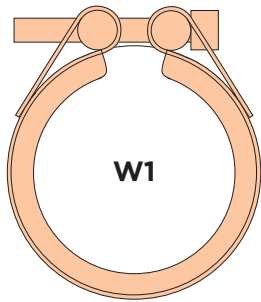

Components	Materials								
	W1		W2		W4		W5		
	DIN	AISI	DIN	AISI	DIN	AISI	DIN	AISI	
Casing	A738 or similar, hot-dip galvanised	1024	1.4404	316 L	1.4301	304	1.4404	316 L	
			or similar	304					or similar
			1.4301	S32101					1.4162
Bolts	1.7220	4135	1.7220	4135	A4 - 80	A4 - 80	A4 - 80	A4 - 80	
Bars	1.0737 galvanised	12L14	1.0737	12L14	1.4404	316 L	1.4404	316 L	
			galvanised	1.4435	316 L	1.4435	316 L		
Anchoring ring	1.4310	301	1.4310	301	1.4310	301	1.4310	301	
			1.4301 (PLAST-GRIP)	304	1.4301 (PLAST-GRIP)	304			
Strip inserts (option)	1.4435 PVDF/HDPE	316 L	1.4435 PVDF/HDPE	316 L	1.4435 PVDF/HDPE	316 L	1.4435 PVDF/HDPE	316 L	

MATERIAL SPECIFICATIONS AND CORROSION RESISTANCE

Material sub group		Class of material	EN	ASTM (AISI)	UNS	Trade name	Yield strength (N/mm ²)	Structure	PRE	Sensitivity compared with hole and crack corrosion
FE1	1		1.4410		S32750	SAF 2507	550	Super Duplex	42.5	extremely low
			1.4547		S31254	254 SMO	320	Super Austenit	44	
			1.4501		S32760	4501	550	Super Duplex	42	
					NO8367	AL-6XN	310	Super Austenit	44	
	2		1.3964				365	Austenit	36	very low
			1.4462		S32205	2205	500	Duplex	34	
			1.4539		NO8904	904L	240	Austenit	37	
	4	W5	1.4401	316	S31600		240	Austenit	25	low
		W5	1.4404	316 L	S31603		240	Austenit	26	
		(V4A) W5	1.4435	316 L	S31603		240	Austenit	29	
		W5	1.4571	316 TI	S31635		240	Austenit	25	
		W5	1.4162	S32101	S32101	LDX 2101	530	Lean Duplex	26	
FE2	(V2A)	W4	1.4301	304	S30400		220	Austenit	19	high
		W4	1.4310	301	S30100		250	Austenit	18	
		W2	1.0737							very high
		W1	1.0570							very high

Duplex ⇒ Ferritic / Austenitic structure
 Lean Duplex ⇒ PRE below 30
 Super Duplex ⇒ PRE over 40

PRE ⇒ $\%Cr + 3.3 \times \%MO + 16 \times \%N$
 (Pitting Resistance Equivalent / Pitting index)

Materials ⇒ DIN86128

CLASSIFICATION OF CORROSIVITY

Corrosivity category (ISO 12944, EN12500)	Application (example)	Corrosivity	Inside	Outdoors	W1	W2	W4	W5 (or better)
C1 - C2	Building construction, building systems, underground car parks	insignificant, low	C1: heated buildings with low air humidity C2: occasional condensation, insignificant air contamination	C1: dry and cold climate zones C2: very rural and generally dry areas	LOW CORROSIVITY			
C3	Building construction, building systems, low environmental demands	moderate	Production areas with intermittent condensation and moderate air contamination	Temperate climates, low air contamination, middle-sized city climate, virtually no road salting				
C4	Process pipes, applications in urban areas	high	Production areas with frequent condensation and moderate air contamination	Industrial and city areas with temperate climate but high air contamination, areas affected by road salting (bridges)				
C5 (C5 - I)	Industrial, areas near industry	very high	Production areas with continuous condensation and/or high air contamination (mines, tunnels)	Temperate climate with high air contamination, particles containing sulphates, soot, dust of unknown composition				
C5 - M (maritime climate)	Shipbuilding, machine rooms, coastal climate roofed	high	Inside damp, often condensation, no chlorides or sulphates	Roofed, no direct precipitation but coastal maritime climate or less than 5 km inland				
C5 - M (maritime climate)	Shipbuilding, bilge, systems, coastal climate open to weather	very high	Condensation, no cleaning of surfaces, high temperatures above 30°C, salts containing chloride or sulphate particles with the possibility of concentration	Open to weather, coastal or off-shore areas, splash water zone, less than 5 km inland, possibly industrial				
Im1 - Im3 (Immersion)	Im1: underground applications	Im2: applications in contact with fresh water, drinking water, municipal sewage system		Im3: applications in sea or brack water				

STRAUB CORROSION PROTECTION

Application of corrosion protection agents depends on the corrosivity category of the environment or of the soil. Generally, W1 and W2 design couplings have to be protected against corrosion if use in soil or corrosive environment is to be expected; please use the classification of corrosivity at the following page.

Our range includes the following corrosion protection material:

- plastic fillers for lock and edge alignment
- corrosion protection strips
- PE protective strips or pipe protection matting against damage from filling material

Pipe couplings in stainless steel do not have to be protected against corrosion under normal environmen-

tal conditions. For galvanised pipe couplings installed in a building with climate control, there is also no need for corrosion protection.

The application of corrosion protection can be undertaken by the STRAUB specialists or the customer. In Germany, a GW15 certification is required.

Assembly of corrosion protection:

STRAUB-COMBI-GRIP (lock part galvanized)



1. Clean the coupling using acetone. On both coupling sides, place a mark at a distance of 10 cm. Apply primer within the two marks.

2. Seal any cavities and transitions using joint sealer, particularly in the lock area. Fill the cavities. Ensure that the transition between coupling and pipe is as smooth as possible.



3. Evenly wrap the inner strip within the two marks.

4. Place the protective strip within the two marks.

Assembly of corrosion protection:

STRAUB-FLEX 2 (casing/lock part galvanized)

1. Mechanically clean the locations to be protected and wipe as dry as possible. If necessary, use a flame to dry any cavities around the lock. Seal any cavities and transitions using joint sealer, particularly in the lock area.

2. Wrap and press the corrosion protection strip around the coupling in three layers; avoid cavities.

3. Apply PE tape onto the corrosion protection strip as mechanical protection. Overlap the strip at 100 mm on both sides.

4. Apply one layer of pipe protection matting around the corrosion protection creating an overlap of approx. 200 mm on both sides. Using a gentle flame, heat the surface under the overlap and press down to fix the matting.





STRAUB COUPLINGS
IN SHIPBUILDING

STRAUB: FLEXIBILITY IN SHIPBUILDING

Shipyards and shipbuilders in particular are continuously faced with the challenge of laying numerous pipes in tight, difficult-to-access areas and are also under pressure to cut costs, production and operating at the same time. In these circumstances an optimum pipe-connecting system is what is called for.

Using STRAUB pipe couplings provides flexibility and numerous cost-effective advantages.

The idea of connecting standard pipes with a flexible joining system without having to work on pipe ends was the brainchild of the company's founder, Immanuel Straub, who, on a visit to a shipyard in Northern Germany realised the potential of introducing a flexible system that did not require work to be undertaken on pipe ends.

Flexibility, compactness, size and weights of maritime products were becoming all the more important in the building of new ships and this in turn influenced Immanuel Straub's pipe connecting concept and led the way to a new era of maritime pipe construction.

The trademarked STRAUB-METAL-GRIP coupling has been developed and successfully launched into the maritime market. Working in conjunction with German shipbuilders and Germanischer Lloyd, the use and application of these flexible, removable and reusable couplings have been thoroughly tested and fully approved.

The German and French Navy were quick to recognise the many benefits of the STRAUB-METAL-GRIP. Being light, space-saving, efficient and quick to install, this innovative coupling system has been installed in their frigates, submarines and aircraft carriers. This has now expanded throughout the world.

Navy shock tests have shown that STRAUB-couplings remain sealed even in a distressed condition (i.e. following a ship collision or an underwater explosion).

This is due to their low weight and is in complete accordance with the principle and classification:

„SAFE TO THE NEXT PORT“

The sea swell can cause significant deformation of the hull and pressure surges in system pipelines whilst the ship is at sea. This leads to a constant strain on the piping systems. Rigid pipe connections such as flanges or welded collars transfer strains directly to other components in the form of stress. Compensators therefore become necessary!

STRAUB PIPE COUPLING COMBINES CONNECTION AND COMPENSATOR ALL IN ONE

The STRAUB design offers pipe flexibility that dissipates stress and increases the component service life. The coupling's rubber sealing gasket efficiently dampens vibrations and noise. Fatigue failures are reduced, system reliability is increased and passenger comfort is much better.

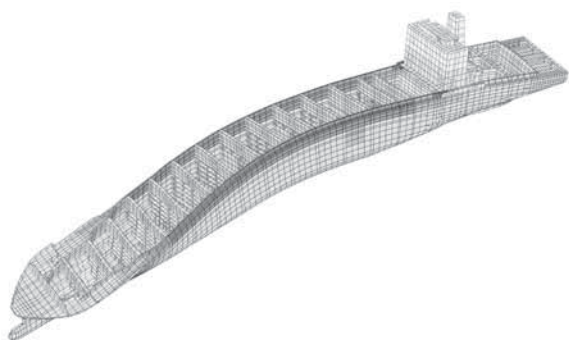

These special properties of STRAUB-GRIP and STRAUB-FLEX couplings represent a decisive added benefit for ship owners and operators.



STRAUB couplings:

- light ▫
- space-saving ▫
- fast and economical ▫
- problem solving ▫

Systems	IACS	Application	Application and restrictions									
			A	B	G	H	I	J	K	L	M	
	According to IACS	Practical usage	Inside machinery space cat. A	Other machinery spaces	Fuel oil tanks	Ballast water tanks	Cofferdams void spaces pipe tunnel and ducts	Accommodation and control space	Open decks	On freeboard deck	Pipes with access to the sea	Inside pipes with access to the sea
Flammable fluids (flash point <60 °C)												
Cargo oil lines	+5)	S	N/A	S	N/A	N/A	F	F	F	F	N/A	N/A
Crude oil washing lines	+5)	S	N/A	S	N/A	N/A	F	F	F	F	F	N/A
Vent lines	+3)	F	F	F	N/A	N/A	F	F	F	F	F	N/A
Insert gas												
Water seal effluent lines	+	S	S	S	N/A	S	S	S	S	S	S	S
Scrubber effluent lines	+	S	S	S	N/A	N/A	S	S	S	S	S	S
Main lines	+2)5)	S	N/A	S	N/A	N/A	F	F	F	F	F	N/A
Distribution lines	+5)	S	F	S	N/A	N/A	S	S	F	F	F	N/A
Flammable fluids (flash point >60 °C)												
Cargo oil lines	+5)	S	F	S	F	N/A	S	S	S	S	S	N/A
Fuel oil lines	+3)2)	F	N/A	F	F	N/A	F	F	F	F	F	N/A
Lubricating oil lines	+2)3)	F	N/A	F	N/A	N/A	F	F	F	F	F	N/A
Hydraulic oil	+2)3)	F	N/A	F	F	N/A	F	F	F	F	F	N/A
Thermal oil	+2)3)	F	N/A	F	F	N/A	F	F	F	F	F	N/A
Sea-water												
Bilge lines	+1)	S	F	S	N/A	S	S	S	S	S	S	N/A
Fire main and water spray	+3)	F	F	F	N/A	F	F	F	F	F	F	N/A
Foam system	+3)	F	F	F	N/A	F	F	F	F	F	F	N/A
Sprinkler system, filled with water	+3)	F	F	F	N/A	F	F	F	F	F	F	N/A
Sprinkler system, not always filled with water	-	dependent from the respective flag state										
Ballast system	+1)	S	F	S	N/A	S	S	S	S	S	S	N/A
Cooling water system	+1)	S	F	S	N/A	S	S	S	S	S	S	N/A
Tank cleaning services	+	S	S	S	N/A	S	S	S	S	S	S	S
Non-essential systems	+	S	S	S	N/A	S	S	S	S	S	S	S
Fresh water												
Cooling water system	+1)	S	F	F	N/A	N/A	S	S	S	S	S	N/A
Condensate return	+1)	S	F	F	N/A	N/A	S	S	S	S	S	N/A
Non-essential systems	+	S	S	S	N/A	S	S	S	S	S	S	S
Sanitary / Drain / Scuppers												
Deck drains	+4)	S	S	S	S	S	S	S	S	S	S	N/A
Sanitary drains	+	S	S	S	S	S	S	S	S	S	S	N/A
Scupper and discharge overboard	-	N/A	N/A	N/A	N/A	N/A	N/A	N/A	N/A	N/A	N/A	N/A
Sounding / Vent												
Water tanks and dry spaces	+	S	S	S	N/A	S	S	S	S	S	S	S
Oil tanks (f.p.>60°C)	+2)3)	F	N/A	F	N/A	F	F	N/A	F	F	F	N/A
Miscellaneous												
Starting control air	-	N/A	N/A	N/A	N/A	N/A	N/A	N/A	N/A	N/A	N/A	N/A
Service air (non-essential)	+	S	S	S	N/A	S	S	S	S	S	S	S
Brine	+	S	S	S	N/A	S	S	S	S	S	S	S
<i>Variations of guidelines and rules by different IACS class companies have to be considered</i>												

Notes:

- +1) Inside machinery spaces cat A, approved fire resistant types only
- +2) Not inside machinery spaces cat A or accommodation spaces; may be accepted in other machinery spaces provided the joints are located in easily visible and accessible points
- +3) Approved fire resistant types
- +4) Above freeboard deck only
- +5) In pump rooms and open decks approved fire resistant types only

- S) STRAUB couplings
- F) STRAUB-FIRE-FENCE
- N/A) Not applicable

THE STRAUB FIRE PROTECTION SYSTEM

The fireproof coupling is a STRAUB-METAL-GRIP, STRAUB-GRIP or STRAUB-FLEX with a fire-protection cover. In the event of fire, the intumescent fire protection coating expands, protectively enclosing the coupling.

During this process, the coupling retains its full operational capability – without any limitations whatsoever.

Despite the fire protection, the STRAUB-FIRE-FENCE can be installed in a space-saving manner. It has a high level of crush resistance, and thanks to the patented design is still remarkably light weight.



The STRAUB-FIRE-FENCE is an impressive and innovative design yet has all the trademarks and properties of traditional classic STRAUB couplings.

We are extremely proud of the fact that our FIRE-FENCE coupling has achieved worldwide certification by the following IACS members according to IACS URP 2 and ISO 19921.



THE STRAUB-FIRE-FENCE KIT

STRAUB couplings that have already been installed can be quickly and easily upgraded to the STRAUB-FIRE-FENCE version using the FIRE-FENCE kit.

Available for models STRAUB-METAL-GRIP, STRAUB-GRIP and STRAUB-FLEX.



ADVANTAGES FOR SHIPBUILDING

SPACE-SAVING

- Requires low storage space
- Good accessibility
- Locking part can be rotated into the optimum fitting position – access only necessary from one side
- Close pipe arrangement possible providing space for other components
- Little space required for later installation

FAST AND ECONOMICAL

- Installation without special tools
- No work required on the pipe ends
- Removable and reusable
- Short installation time and minimum downtime
- High assembly tolerances

MULTI-PURPOSE

- Connects the broadest variety of pipe materials and different diameters
- Can be used for pressure, drainage and suction pipes

SAFE

- No risk of fire or explosion during installation
- No costs for safety measures
- Quadruple safety factor
- STRAUB has all IACS approvals
- Flexible design absorbs overstressing



👍 DAMPING

- Plenty of rubber to absorb vibrations/oscillations
- Reduces pressure blows
- Reduces fatigue failures
- Noise reduction increases passenger comfort

👍 TENSION-FREE

- Increases the life of fittings and systems
- Compensates for axial displacement and misalignment
- Coupling and compensator in one

👍 LONG LIFE

- Corrosion resistant
- Good resistance to heat and chemicals
- Low torque guarantees long life

👍 LIGHT

- Light weight
- Low transport costs
- Increases the payload



Flanged connection:
8.6 kg



STRAUB connection:
2.1 kg



OUR SOLUTIONS - YOUR BENEFIT

REFERENCES

PASSENGER SHIP



Cruise ship | „Carnival Splendor“ (Italy)

Our solution:

- STRAUB-GRIP-L and STRAUB-METAL-GRIP
- fire main, grey water and black water lines

Customer benefit:

- short down times due to fast and simple installation
- safety
- factor 4
- high dampening capacity increases passenger comfort

YACHT



„MY Trippel Seven“ (Germany)

Our solution:

- STRAUB-GRIP-L and STRAUB-METAL-GRIP
- seawater cooling, fire main, grey water and black water lines

Customer benefit:

- simple and safe installation

WARSHIPS



Frigate | „Horizon 6108“ (Italy)

Our solution:

- STRAUB-GRIP-L and STRAUB-METAL-GRIP
- CuNiFe seawater, vent, grey and black water, sprinkler lines

Customer benefit:

- high product quality
- simple installation,
- technical advantages (dampens vibration, shock absorbing, angular deflection possible, collision and shockproof, flexible compensation of endload)

Others: aircraft carrier, deployment provider, marine tanker, submarine

FERRY



Fast ferry | „N.G.V Asco“ (France)

Our solution:

- STRAUB-GRIP-L, STRAUB-METAL-GRIP and STRAUB-COMBI-GRIP
- Ballast, bilge, fire main, seawater, freshwater and fuel lines

Customer benefit:

- Possibility to join various pipe materials, STRAUB offers a lightweight and absorbing product.

PSV PLATFORM SUPPLY VESSELS



Others: AHT Anchor Handling Tugs, AHTS Anchor Handling Tugs Supply Vessel

„Bourbon Hamos“ GPA 670 MKII (Designer: GPA USA)

Our solution:

- STRAUB-GRIP-L
- dry bulk, fresh water, fuel lines

Customer benefit:

- easy cleaning of dry bulk lines
- space saving and flexible
- pipe joining method

OIL PRODUCTION



Others: drilling ships, FPSO

Offshore- and Production Platform | „Xitebjorn“ (Norway)

Our solution:

- STRAUB-METAL-GRIP
- various pipe lines

Customer benefit:

- absorption of pressure surges and stress peaks

CARGO SHIPS



Others: RoRo ships, bulk carriers, container ships, refrigerator ships, LNG tankers

Transport ship | „Wagenborg“ (Netherlands)

Our solution:

- STRAUB-GRIP-L
- ballast lines

Customer benefit:

- installation of couplings possible without special tooling even in places difficult to access
- increased payload

INLAND WATER VESSEL



Paddle wheel steamer | „La Suisse“ (Switzerland)

Our solution:

- STRAUB-GRIP-L and STRAUB-FLEX
- fresh water, fire main, vent line

Customer benefit:

- The vessel is built mainly in wood. Due to risk of explosion and fire, welding was not possible.

SPECIAL VESSELS

Floating dredger
„Vasco da Gama“ (Netherlands)

Others: research vessel, icebreaker

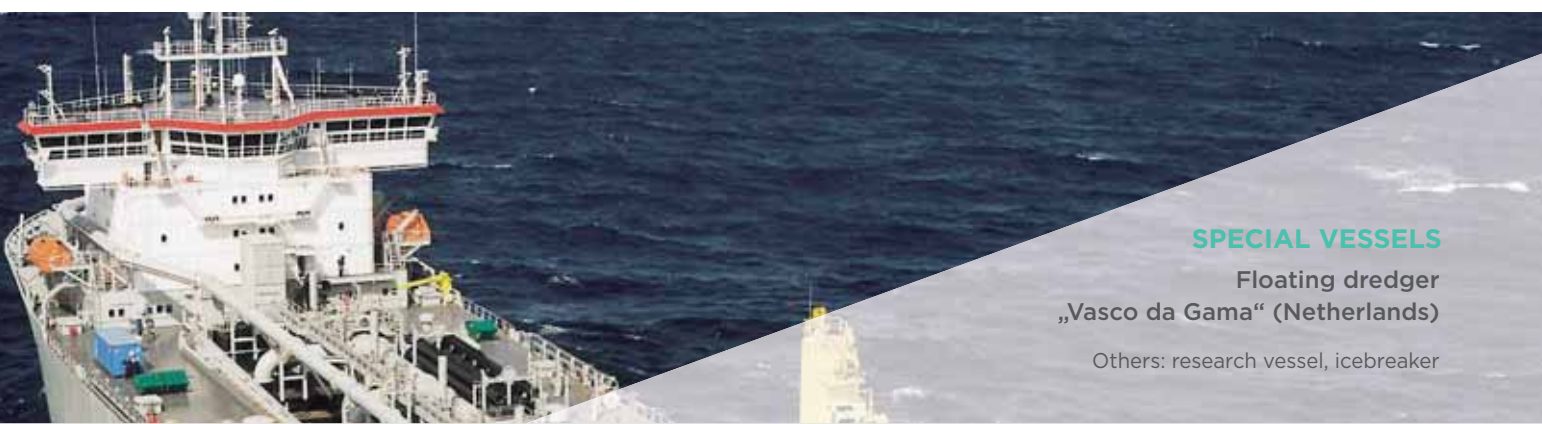

OUR APPROVALS

STRAUB pipe couplings have been tested by all leading national and international classification societies and approved for almost all pipe systems and in shipbuilding.



The necessary approvals for this are based on the following tests:

- **Tightness test**
1.5 x PN
5 min. tight
- **Vibration test**
1 x PN
3 x 10⁶ cycles
Amplitude 0.06 / 0.5 / 1.5 mm
Frequency 100 / 45 / 10Hz
- **Burst pressure test**
4 x PN
5 min. tight
- **Pull-out-test**
1x PN + F_{ax} (PN as appropriate)
5 min. without leakage or other faults
- **Fire-endurance test** (in accordance with ISO 19921 and 19922)
1 x PN
30 min.
800°C
pressure test: 2 x PN; 5 min. tight
- **Vacuum test**
170 mbar absolute
5 min. tight
- **Repeated assembly test**
10 x assembly and dismantling
1.5 x PN pressure test
5 min. tight
- **Shock test**
Acceleration 140 g surface ships
Acceleration 200 g submarines
(for CuNiFe and C steel pipes)
- **Angular deflection test**
Angular deflection 20°
20 bar; Ø 114.3 mm
5 min. tight



▪ **Jump test**

1 x PN

Impact of 100 kg weight on coupling

No leakage

Angular deflection approx. ca. 20°



STRAUB
the right  **connection**



BENEFIT FROM OUR INTERNATIONAL CONNECTIONS



WORLDWIDE BRANCH OFFICES: WORLDWIDE WITH STRONG PARTNERS

Users all over the world in more than 60 countries place their trust in the universal STRAUB pipe coupling concept and benefit from our engineering competency and project experience. The Canadian subsidiary, an international partner network and a large number of support bases around the whole world guarantee the shortest possible delivery times and competent consultancy on site. Products are also manufactured under licence in Japan and Brazil.

Wherever you are, you can benefit from our international connections!

A list of our partners is available on the Internet at www.straub.ch



TECHNICAL SHORT CHECK LIST

Issued by: _____

Client: _____

Date: _____

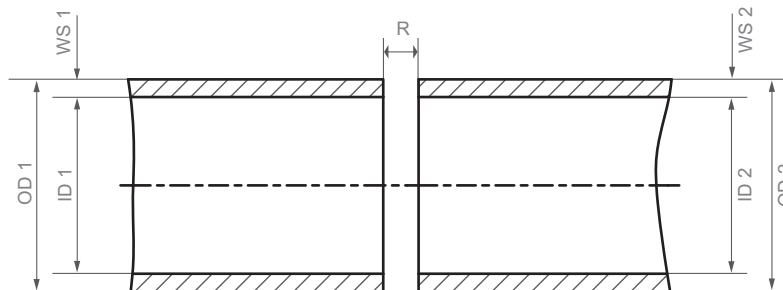

<p>Dimensions 1: OD 1 _____ mm ID 1 _____ mm or WS 1 _____ mm or SDR1 no _____</p> <p>Material 1:</p> <ul style="list-style-type: none"> <input type="checkbox"/> carbon steel <input type="checkbox"/> SS <input type="checkbox"/> GRP <input type="checkbox"/> PE / PP <input type="checkbox"/> PVC <input type="checkbox"/> _____ 	<p>Dimensions 2: OD 2 _____ mm ID 2 _____ mm or WS 2 _____ mm or SDR2 no _____</p> <p>Material 2:</p> <ul style="list-style-type: none"> <input type="checkbox"/> carbon steel <input type="checkbox"/> SS <input type="checkbox"/> GRP <input type="checkbox"/> PE / PP <input type="checkbox"/> PVC <input type="checkbox"/> _____
<p>Kupplung:</p> <ul style="list-style-type: none"> <input type="checkbox"/> pull-out resistant (GRIP) <input type="checkbox"/> axially flexible (FLEX) <input type="checkbox"/> repair type (OPEN-FLEX) <p>Medium:</p> <ul style="list-style-type: none"> <input type="checkbox"/> air <input type="checkbox"/> water <input type="checkbox"/> gas <input type="checkbox"/> fuel <input type="checkbox"/> chemical products <p>Specification: _____ Chemical formula: _____ Concentration: _____</p>	<p>Casing: <input type="checkbox"/> ss <input type="checkbox"/> galv.</p> <p>Lock part: <input type="checkbox"/> ss <input type="checkbox"/> galv.</p> <p>Pressure: working pressure _____ bar test pressure _____ bar (system pressure) _____ bar vacuum _____ mbar</p> <p>Temperature (medium): max. _____ °C min. _____ °C</p> <p>Pipe gap: R max. _____ mm</p>
<p>Quantities required: _____</p>	
<p>Remarks:</p> <p>_____</p> <p>_____</p> <p>_____</p>	

STRAUB solution: _____
 (to be completed
 by STRAUB) _____

Issued by: _____ Date: _____

SALES AND DELIVERY CONDITIONS

PURCHASE ORDER

These conditions of sale and delivery shall apply unless otherwise exceptionally agreed and confirmed in writing for an individual specific case. Alternative contractual conditions set down by the purchaser shall not be binding on us unless exceptionally agreed to and confirmed in writing by us.

All quotations set out in our offers and price lists shall be understood to be unconditional and shall only become binding on us up to the expiry of the term that we have specified for the acceptance of the contract.

We can not accept responsibility for any damage or loss to drawings, samples, models, etc. provided by the purchaser with the exception of such damage or loss caused through malice or gross negligence.

Any technical documentation and samples produced by us shall remain our property and shall not be reproduced or be made available to a third party. These items, together with the offer shall be treated in confidence. Should an associated order not ensue we reserve the right to request the return of all relevant material.

PRICES

Our prices are based on raw material costs and wage rates valid at the time. We reserve the right to take changes in costs expressly into account up to the time of delivery. Unless stated otherwise, all our prices are always quoted as being without packaging, exworks.

PAYMENT CONDITIONS

- a) 30 days from date of invoice without any deduction
- b) Pre-payment
- c) against irrevocable letter of credit, confirmed by the UBS AG, Oerlikon branch, 8050 Zurich, Switzerland, payable 30 days from the date of confirmation of delivery by the forwarding agency. All bank charges abroad shall be absorbed by the purchaser. Letter of credit validity: 8 weeks from date of delivery.

RETENTION OF TITLE

The supplier shall remain the property owner of the whole delivery until such times as payments have been made in full by the customer as set down in the purchase agreement. Straub shall be empowered by the customer, through the successful conclusion of the contract and at the customer's cost, to record ownership of the goods purchased in official registers, ledgers or similar in cognizance of applicable local law.

DELIVERY TERMS

Our information concerning delivery terms is calculated from the date of written confirmation of order or from receipt of prepayment or from confirmation of the letter of credit, alternatively start-

ing with the finalisation of the contract though not before receipt of the necessary documentation from the customer. Every endeavour will be made to keep to the delivery terms quoted although they shall not be considered legally binding.

DELIVERY

A portion of our products are delivered packed only in standard boxes. Our customers shall therefore be obliged to accept any resultant tolerance on quantities. As a manufacturing undertaking we cannot accept the return or consider the exchange of over- or wrongly-ordered goods. Should a minimum quantity be absolutely necessary then this is to be noted specially on the purchase order.

TRANSFER OF USAGE AND RISK

Shipment of the goods shall be at the expense and risk of the purchaser. Said shipment shall be at the expense and risk of whomsoever places the order when we take care of the transport arrangements.

INSURANCE

Arrangements for any legally required public liability and material insurance in the country of destination for our products shall be the concern of the client. We explicitly cannot accept any responsibility for failure to make the necessary arrangements for such insurance protection.

TOOLS

Through the payment of partial costs for tools, the customer shall acquire the exclusive right to the parts produced therewith although having no claim to the tools themselves; they remain the property and in possession of the supplier (see also our special conditions concerning this matter). Tool replacements and modification shall be at the customer's expense. We shall be free to dispose of the tools as we see fit in the event of no follow-up order within a period of (5) five years.

CHECKING AND ACCEPTANCE OF THE DELIVERY

The customer shall promptly check the delivery upon receipt and notify us in writing of any shortcomings within a period of 8 (eight) days. Failure to do so shall be taken to mean that the delivery is accepted.

GUARANTEE

Straub couplings and components thereof that exhibit constructional or material faults will be replaced free-of-charge or be credited to the customer during a period of 5 years (exceptions: STRAUB-CLAMP, STRAUB-REP-FLEX, STRAUB-PLAST-PRO and STRAUB-ECO-GRIP ⇒ 2 years) reckoned from the date of dispatch from the factory. Should a complaint concerning our products arise for the specified reasons within the guarantee period, they shall be re-

turned to our factory in 7323 Wangs/SG, Switzerland where they can be examined. Replacement of a faulty coupling or component part thereof shall only take place following the report from our testing department, which shall be final and incontestable. Our guarantee warranty shall not apply to couplings that have been installed without due observance of our assembly instructions. This shall also apply even in the face of contrary purchase conditions on the part of the customer.

LIABILITY

We shall only be held liable within the limits of the legally binding requirements for damage that is not covered by the guarantee conditions, especially for consequential damage resulting from defects concerning faulty construction or the defective function of pressed and spring parts or assembled couplings manufactured in our factory as well as from the responsibility of the producers. We expressly cannot be held liable for corrosion damage on the coupling or damage in connection with components that were not manufactured in our factory.

CHANGES TO THE ORDER BY THE CUSTOMER

In the case of a contractually agreed change to the present order by the customer (quantity, dimensions, material, etc.) we shall have the right to invoice the customer for already finished items and/or raw materials or piece parts that are no longer usable for the modified order.

PATENTS / COPYRIGHT

The customer is hereby obliged to exonerate us from any claim by a third party arising from an infringement of a patent, registered design or other protected or copyrighted matter.

LOCATION OF CONTRACTUAL FULFILMENT

The customer is hereby obliged to exonerate us from any claim by a third party arising from an infringement of a patent, registered design or other protected or copyrighted matter.

SEAT OF JUSTICE AND APPLICABLE LAW

Wangs, Switzerland shall be considered to be the location of contractual fulfilment for both parties for all rights and obligations arising from this legal transaction.

ACCEPTANCE

Unless reported to the contrary within 10 (ten) days, the above sales and delivery conditions shall be taken as being accepted by the customer. In case of linguistic lacks of clarity the german version of these Sales and Delivery Conditions is valid.

LIABILITY DISCLAIMER

The information and data in this manual are intended to assist the user in the proper selection of STRAUB products. This information may contain inaccuracies or typographical errors. Furthermore, all the information contained in this manual list is subject to change by STRAUB Werke AG without prior notice as a result of product re-designs, product improvements or other reasons.

STRAUB Werke AG accepts no liability for damage arising as a result of the use of data, diagrams or application examples in this manual.



OUR QUALITY PRODUCTS - YOUR ADDED VALUE

We obtained the ISO 9001 Quality Assurance Certificate in 1995 and ISO 14001 in 2008. This confirms proven STRAUB quality and made us once again world pioneers in the area of progressive sealing pipe joints.



STRAUB Werke AG
Straubstrasse 13 - 7323 Wangs - Switzerland
Phone +41 81 725 41 00 - Fax +41 81 725 41 01
straub@straub.ch

www.straub.ch

